

robin
اسکنر بارکود
Barcode Scanner



User Guide

**Robin RS 1100
Scanner**

.by robin Auto-ID Tech. Co., Ltd. All rights reserved 2012 ©

Please carefully read the manual before use the product, andeffectively to protect the safety of products operation. Please keep this manual after reading properly and save for the next reading.

Do not disassemble the device or tearing the seal label on the device.Otherwise, FuJian robin Auto-ID Tech. Co., Ltd. does not .assume responsibility for the warranty or replacement

The pictures in this manual are for reference only. If the individual picture from the actual product was different with this manual, please refer to actual product. Regarding to the product modification and update, FuJianNewland Auto-ID Tech. Co., Ltd. reserves the right to make changes to any software or product to improve reliability, function, or design at any time without notice.

This manual contains all the information is protected by copyright. Any Company and individuals should not in any way or reason for any form of extract, copy, sell all or part of this document without written permission.

Revision History

Changes to the original manual are listed below:

| Revrision | Description | Change Date |
|-----------|---|-------------|
| Ver 1.0 | Initial Version | 2011-12-25 |
| Ver 1.1 | Modify text mistakes. Adjust the format of Start/Exit Setup | 2012-08-10 |

Table of Contents

| | |
|---|----|
| Preface..... | 1 |
| Introduction..... | 1 |
| Chapter Descriptions | 1 |
| Document Set | 1 |
| Chapter 1 Getting Started | 2 |
| Introduction..... | 2 |
| Unpacking..... | 2 |
| Product OverView..... | 2 |
| Interface..... | 3 |
| Communication Port..... | 4 |
| UsingUSB Cable..... | 5 |
| Using RS232 Cable..... | 5 |
| Using PS/2 Cable | 6 |
| Remove the Communication Cable | 6 |
| Power-on, Power-off, Sleep, Reboot..... | 7 |
| Power-on | 7 |
| Power-off..... | 7 |
| Sleep | 7 |
| Reboot..... | 7 |
| Reading Window Maintenance..... | 7 |
| Reading Depth of Field..... | 8 |
| Specification | 9 |
| Overview..... | 10 |
| Left View | 10 |
| Front View..... | 10 |
| Vertical View | 10 |
| Barcode Reading..... | 11 |
| Chapter 2 General Configuration | 12 |
| Introduction..... | 12 |
| Setting Barcode | 12 |
| Setting Command..... | 12 |
| Format of Setup Barcode | 12 |
| Use the Setting Barcodes | 13 |
| Use the Setup Command..... | 13 |
| Setup State | 13 |
| Setup Protocol | 14 |
| SetupProcess Flow | 15 |
| Default Setup | 16 |

| | |
|--|----|
| Factory Default Setting | 16 |
| Work Mode Selection | 16 |
| Reading Mode | 16 |
| Manual Scanning Mode | 16 |
| Auto Scanning Mode | 17 |
| Intermittent Reading Mode | 18 |
| Sense Reading Mode | 18 |
| Continuous Reading Mode | 19 |
| Extended Sense Reading Mode | 20 |
| Command Triggered Reading Mode | 20 |
| Security Level Setup | 21 |
| Decoding Sound Setup | 21 |
| Other Setup | 22 |
| Activate/Abort Temporary Mute | 22 |
| Chapter 3 Inquiry Command | 23 |
| Introduction | 23 |
| Chapter 4 Communication Setup | 24 |
| Serial Port Setup | 24 |
| Baud Rate Setup | 24 |
| Check Setup | 25 |
| Stop Bit | 25 |
| Flow Control Setup | 25 |
| Data Bit | 25 |
| USB Function Setup | 26 |
| USB Virtual Keyboard Function | 26 |
| USB Virtual Serial Port Function | 27 |
| Keyboard Function Setup | 28 |
| Keyboard Layout | 28 |
| Set the Delay between Characters | 28 |
| Character Conversion | 29 |
| Chapter 5 Data Format Setup | 30 |
| Introduction | 30 |
| Prefix Sequence Setup | 30 |
| Custom Prefix | 30 |
| Add Custom Prefix or Not | 30 |
| Define the Custom Prefix | 31 |
| AIM ID Prefix | 31 |
| Code ID Prefix | 31 |
| Custom Suffix | 32 |
| Add Custom suffix or Not | 32 |

| | |
|---|----|
| Define the Custom suffix | 32 |
| End Mark Suffix | 33 |
| Add End Mark Suffix or Not..... | 33 |
| Define the End Mark Suffix | 33 |
| Chapter 6 Barcode Parameter Setup | 35 |
| Introduction..... | 35 |
| Code 128 | 35 |
| Restore Default Value | 35 |
| Allow to Read Code 128 or not..... | 35 |
| Code ID Setup | 35 |
| Set the Barcode Reading Length..... | 36 |
| UCC/EAN-128..... | 37 |
| Restore Default Value | 37 |
| Allow to Read UCC/EAN-128 or not | 37 |
| Code ID Setup | 37 |
| Set the Barcode Reading Length | 37 |
| AIM 128..... | 38 |
| Restore Default Value | 38 |
| AIM 128 Allow to Read AIM-128 or not | 38 |
| Code ID Setup | 39 |
| Set the Barcode Reading Length | 39 |
| EAN-8..... | 40 |
| Restore Default Value | 40 |
| Allow to Read EAN-8 or not | 40 |
| Code ID Setup | 40 |
| Set Whether or not to Read 2-Digit Extracode..... | 40 |
| Set Whether or not to Read 5-Digit Extracode..... | 41 |
| Set Whether or not to Send the Check Digit..... | 41 |
| EAN-13 | 42 |
| Restore Default Value | 42 |
| Allow to Read EAN-13 or not..... | 42 |
| Set Whether or not to Send the Check Digit..... | 42 |
| Code IDSetup..... | 42 |
| Set Whether or not to Read 2-Digit Extracode..... | 43 |
| Set Whether or not to Read 5-Digit Extracode..... | 43 |
| Extended Setup | 43 |
| ISSN | 44 |
| Restore Default Value | 44 |
| Allow to Read ISSN or not..... | 44 |
| CodeID Setup..... | 44 |

| | |
|---|----|
| ISBN..... | 45 |
| Restore Default Value | 45 |
| Allow to Read ISBN or not..... | 45 |
| ISBN Data Length Setup | 45 |
| CodeIDSetup..... | 45 |
| UPC-E | 46 |
| Restore Default Value | 46 |
| Allow to Read UPC-E or not | 46 |
| Set Whether or not to Send the Check Digit..... | 46 |
| CodeID Setup..... | 46 |
| Set Whether or not to Read 2-Digit Extracode..... | 47 |
| Set Whether or not to Read 5-Digit Extracode..... | 47 |
| Set Whether or not to Transmit the System Character "0" | 48 |
| Extension Setup..... | 48 |
| UPC-A | 48 |
| Restore Default Value | 48 |
| Allow to Read UPC-A or not..... | 49 |
| CodeID Setup..... | 49 |
| Set Whether or not to Transmit the Check Digit..... | 49 |
| Set Whether or not to Transmit the System Digit "0" | 49 |
| Set Whether or not to Read 2-Digit Extracode..... | 50 |
| Set Whether or not to Read 5-Digit Extracode..... | 50 |
| Interleaved 2 of 5..... | 51 |
| Restore Default Value | 51 |
| Allow to Read Interleaved 2 of 5 or not | 51 |
| Code ID Setup | 51 |
| Set Whether or not to Transmit the Check Character | 51 |
| Set the Barcode Reading Length | 52 |
| ITF-6..... | 53 |
| Code ID Setup | 53 |
| ITF-14..... | 54 |
| CodeIDSetup..... | 54 |
| Deutsche 14 | 55 |
| Restore the Default Value | 55 |
| Allow to Read Deutsche14 or not..... | 55 |
| CodeID Setup..... | 55 |
| Deutsche 12 | 56 |
| Restore the Default Value | 56 |
| Deutsche 12 Allow to Read Deutsche 12 or not..... | 56 |
| CodeID Setup..... | 56 |

| | |
|---|----|
| COOP 25(Japanese Matrix 2 of 5)..... | 57 |
| Restore the Default Value | 57 |
| Allow to Read COOP 25 or not..... | 57 |
| CodeID Setup..... | 57 |
| Check Setup..... | 58 |
| Set the Barcode Reading Length | 58 |
| Matrix 2 of 5 (European Matrix 2 of 5)..... | 59 |
| Restore the Default Value | 59 |
| Restore the Default Setup Value of Matrix2 of 5..... | 59 |
| CodeID Setup..... | 59 |
| Check Setup..... | 60 |
| Set the Barcode Reading Length | 60 |
| Industrial 25..... | 61 |
| Restore the Default Value | 61 |
| Allow to Read Deutsche 12 or not..... | 61 |
| CodeID Setup..... | 61 |
| Check Setup..... | 62 |
| Set the Barcode Reading Length | 62 |
| Standard 25..... | 63 |
| Restore the Default Value | 63 |
| Allow to Read Standard 25 or not | 63 |
| CodeID Setup..... | 63 |
| Check Setup..... | 64 |
| Set the Barcode Reading Length | 64 |
| Code 39 | 65 |
| Restore the Default Value | 65 |
| Allow to Read Code 39 or not..... | 65 |
| CodeID Setup..... | 65 |
| Check Setup..... | 66 |
| Set whether to Send the start and stop character or not | 66 |
| Set the Reading Range of ASCII Code | 66 |
| Set the Barcode Reading Length | 67 |
| Codabar | 67 |
| Restore the Default Value | 67 |
| Allow to Read Codabar or not..... | 68 |
| CodeID Setup..... | 68 |
| Check Setup..... | 68 |
| Start and Stop Character Setup..... | 69 |
| Set the Barcode Reading Length | 69 |
| Code 93 | 70 |

| | |
|---------------------------------------|----|
| Restore the Default Value | 70 |
| Allow to Read Code 93 or not..... | 70 |
| CodeID Setup..... | 71 |
| Check Setup..... | 71 |
| Set the Barcode Reading Length | 72 |
| Code 11..... | 72 |
| Restore the Default Value | 72 |
| Allow to Read Code 11 or not..... | 72 |
| CodeID Setup..... | 73 |
| Check Setup..... | 73 |
| Set the Barcode Reading Length | 74 |
| Plessey | 75 |
| Restore the Default Value | 75 |
| Allow to Read Plessey or not..... | 75 |
| CodeID Setup..... | 75 |
| Check Setup..... | 75 |
| Set the Barcode Reading Length | 76 |
| MSI-Plessey | 76 |
| Restore the Default Value | 76 |
| Allow to Read MSI-Plessey or not..... | 77 |
| CodeID Setup..... | 77 |
| Check Setup..... | 77 |
| Set the Barcode Reading Length | 78 |
| GS1 Databar | 79 |
| Restore the Default Value | 79 |
| Allow to Read GS1 Databar or not..... | 79 |
| CodeID Setup..... | 79 |
| PDF417..... | 79 |
| Restore the Default Value | 79 |
| Allow to Read PDF417 or not..... | 80 |
| CodeID Setup..... | 80 |
| MicroPDF417 | 80 |
| Restore the Default Value | 80 |
| Allow to Read MicroPDF417 or not..... | 80 |
| CodeID Setup..... | 81 |
| Chapter 7 Appendix | 82 |
| Default Setup Table..... | 82 |
| AIM ID Table..... | 90 |
| CodeID Table | 92 |
| Data Barcode | 93 |

Save and Abort the Setup 94

Preface

Introduction

This manual provides information about using the NLS-HR15 series 1D barcode corded scanner: NLS-HR15XX-3E. (Hereinafter refer to as “HR15 corded scanner”)

Chapter Descriptions

- ✧ *Chapter1, Getting Started* : General description of HR15 corded scanner including all the parameters of HR15 corded scanner.
- ✧ *Chapter2, General Configuration* : This chapter introduces the method of how to set the HR15 corded scanner. There are two methods, setup barcode and setup command.
- ✧ *Chapter3, Inquiry Command* : This chapter introduces how to inquiry and obtain the information of HR15 corded scanner by scanning the setup barcode.
- ✧ *Chapter4, Communication Setup* : Serial port parameter setup and USB function setup have been introduced in this chapter.
- ✧ *Chapter5, Data Format* : Introduces how to use the prefix and suffix to satisfy the customers' requirement to obtaining more barcode data.
- ✧ *Chapter6, Barcode Parameter Setup* : In this chapter, all the barcodes which HR15 scanner supports have been listed, and the relevant parameter setup barcodes have been provided.

Document Set

The documentation set for the NLS-HR15 corded scanner provides information for specific user needs and includes:

- ✧ ***NLS-HR15XX-3E Quick Start Guide*** : Description how to get the HR15 corded scanner up and basic operation.
- ✧ ***NLS-HR15XX-3E User Guide*** : This is the manual, description how to use and set the HR15 corded scanner.
- ✧ ***Software Utilities User Guide*** : Description how to use the Newland's scanner utilities software developed tool.

Chapter 1 Getting Started

Introduction

HR15 corded scanner is a type of 1D barcode scanner with excellent performance, except for all the normal 1D barcode, it also can read the stacked 2D barcode such as PDF417 and the MicroPDF17. Based on the self-independent technology **UIMG™** of robin, HR15 corded scanner is able to perform rapid image acquisition and accurate decoding; it can provide the customers with best service. HR15 corded scanner is designed in accordance with the human engineering, which makes it easier and more comfortable to use.

The introduction of how to use the HR15 corded scanner is included in this chapter with several pictures, if you have a HR15 corded scanner in your hand, please compare the real scanner with this manual, which will help you to understand this manual better. This chapter is applicable to normal users, maintenance staff and software developer.

Unpacking

Open the package and take out HR15 corded scanner and its accessories. Please check the completeness of all the items according to the package list, and make sure there are no damaged parts. If any contents are damaged or missing, please keep the original package and contact your dealer immediately for after-sale service.

Product Overview

The main parts of HR15 are shown in the following picture

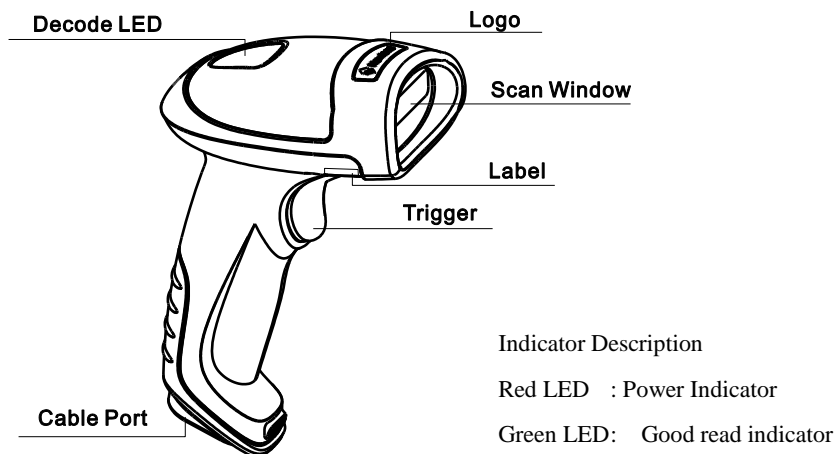

Interface

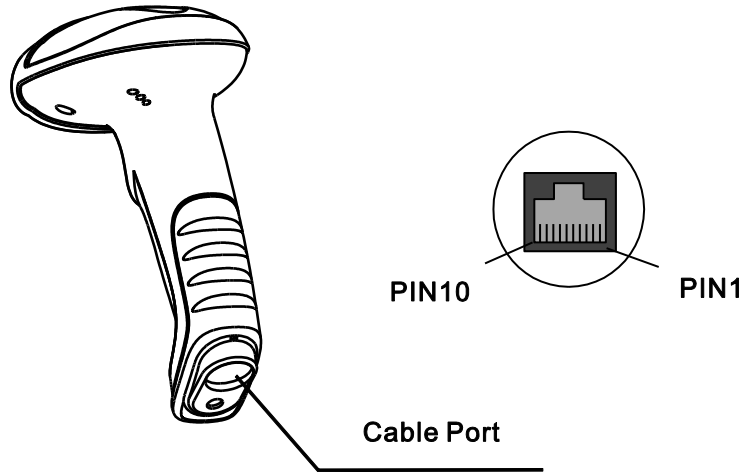

Pin assignment Definition 1 of HR15 connector (factory default)

| PIN | Definition | Type | Description |
|-----|------------|------|-----------------------|
| 1 | NC | - | Null |
| 2 | NC | - | Null |
| 3 | VCC | P | Power : +5V |
| 4 | TXD | O | RS232 Output |
| 5 | RXD | I | RS232 Input |
| 6 | CTS | I | Stream Control Signal |
| 7 | RTS | O | |
| 8 | GND | P | Ground |
| 9 | D- | I/O | USB Signal |
| 10 | D+ | I/O | |

Pin assignment Definition 2 of HR15 connector

| PIN | Definition | Type | Description |
|-----|------------|------|-----------------------|
| 1 | CLK1 | I/O | Keyboard Clock Signal |
| 2 | DATA1 | I/O | Keyboard Data Signal |
| 3 | VCC | P | Power : +5V |
| 4 | TXD | O | RS232 Output |
| 5 | RXD | I | RS232 Input |
| 6 | CLK2 | I/O | PC Clock Signal |
| 7 | DATA2 | I/O | PC Keyboard Signal |
| 8 | GND | P | Ground |
| 9 | D- | I/O | USB Signal |
| 10 | D+ | I/O | |

Communication Port

HR15 must be connected with a host for further operation, such as PC, POS.or any intelligent terminal with USB, RS232 or PS/2 interface.

- ✧ USB

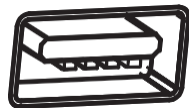

USB interface on the host

- ✧ RS232



RS232 interface on the host

✧ PS/2



PS/2 interface on the host

Please check the port on the host and purchase the right cable.

Using USB Cable

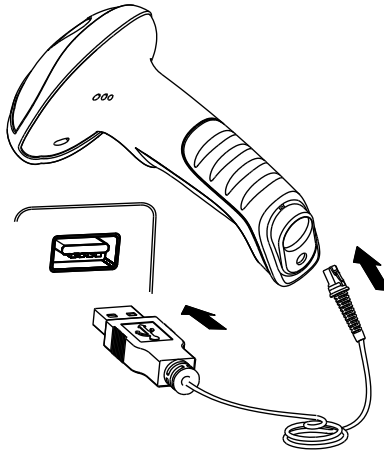

Connecting the HR15 corded scanner with host through USB cable:

- 1 Plug the RJ45 connector into HR15 scanner.
- 2 Plug the USB connector into Host.

Using RS232 Cable

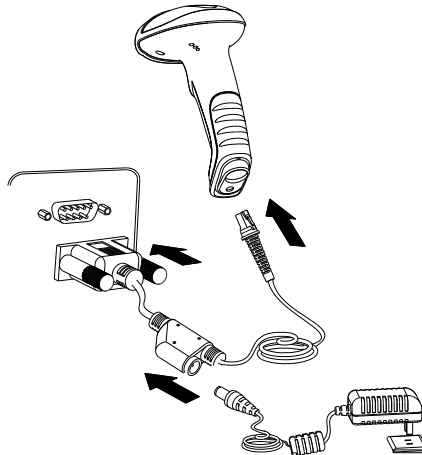

Connecting the HR15 corded scanner with host through RS232 cable:

- 1 Plug the RJ45 connector into HR15 scanner.
- 2 Plug the RS232 connector into Host.
- 3 Connect the RS232 cable with power adapter.

Using PS/2 Cable

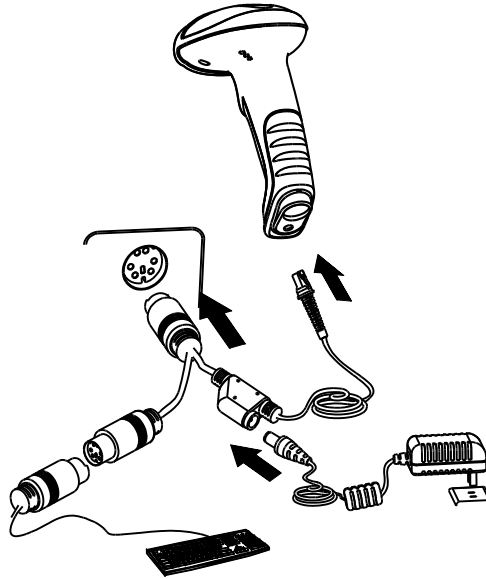

Only the HR15XX-33 corded scanner support the PS/2 interface,

- 1 Plug the RJ45 connector into HR15 scanner.
- 2 Plug the PS/2 connector into Host.
- 3 If necessary, please connect the PS/2 cable with power adapter.
- 4 If necessary, please connect the normal keyboard with PS/2 cable.

Remove the Communication Cable

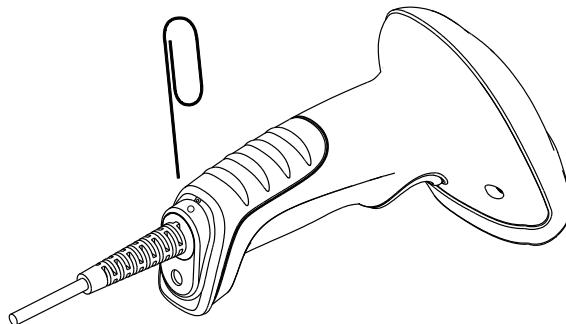

Follow the figure instruction, use a paper clip or spicule to push into the disassemble hole to remove the cable from HR15.

- 1 Please remove the power adapter first, if use RS232 or PS/2 cable connects with.
- 2 Insert and push the spicule into the disassemble hole.
- 3 Pull out the cable and remove the spicule form the hold.

Power-on, Power-off, Sleep, Reboot

Power-on

Connect the HR15 with the host, the HR15 will power on automatically (factory default).

Power-off

There is three ways to turn off the scanner :

- ✧ Remove the cable connected from the HR15.
- ✧ Remove the cable connected from the Host PC.
- ✧ Remove the power adapter connected from the RS232 cable.

Sleep

The scanner will become into sleep mode if no scanning is carried out in a period of time.

Reboot

If the HR15 no response or abnormal, please pull out the cable from Host PC then plug again to reboot the HR15.

Reading Window Maintenance

- ✧ The scanning window should keep clean.
- ✧ Avoid hard and rough objects to clean the reading window that will easy to cause the damage or scratch.
- ✧ Use soft brush to remove the stain on the scanning window.
- ✧ Please use the soft cloth to clean the window, such as glassed cleaning cloth.
- ✧ It is prohibited to spray liquid on the scanning window.
- ✧ It is prohibited to use any detergent except for water.

Reading Depth of Field

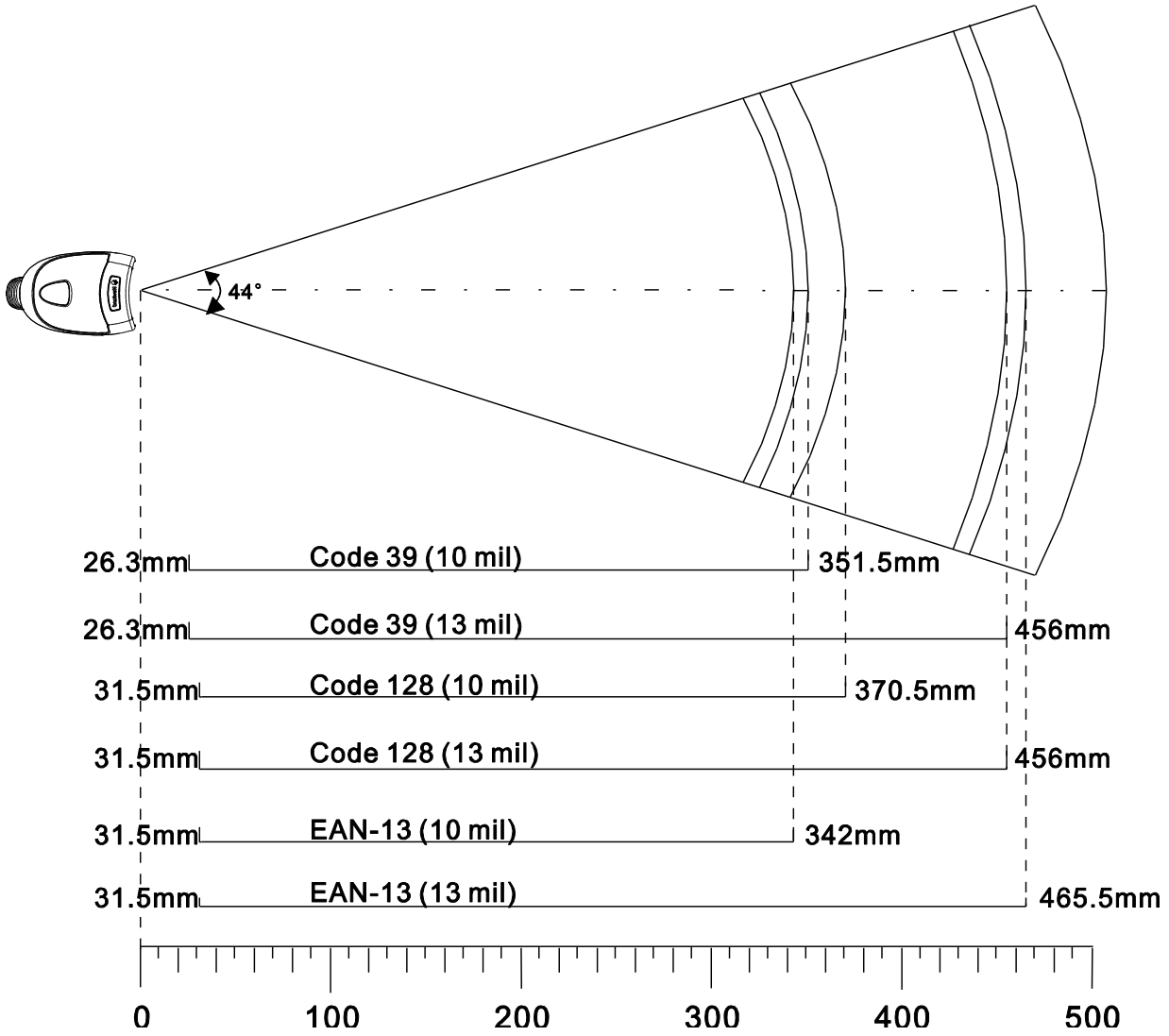

Specification

Performance

| | |
|--------------------------------|---|
| Light Source | 620nm Visible Red LED |
| Scan Pattern | CCD linear image |
| Symbologies | Code128, EAN-13, EAN-8, Code39, UPC-A, UPC-E, Codabar, Interleaved 2 of 5, ISBN, Code 93, UCC/EAN-128, GS1 Databar, PDF417, MicroPDF417, etc. |
| Resolution | ≥ 4 mil |
| Scan Angle | 44 ° |
| Reading Angle | 44 ° |
| Scan Rate | 300 scans per second |
| Minimum Symbol Contrast | 20% |
| Reminder | Beep and LED indicator |
| Interface | RS-232, USB 1.1, PS2 |

Mechanical

| | |
|---|--|
| Dimensions of Scanner(L x W x H) | 113.5 x 73 x 159 mm |
| Dimensions of Cradle(L x W x H) | 195 x 82.5 x 47 mm |
| Weight of Corded Scanner | 152 g |
| Reminder | Beep and LED indicator |
| Power Adaptor | Output: DC5V, ≥1.5A, Input: AC 100~240V, 50~60Hz |

Environmental

| | |
|------------------------------|--|
| Operation Temperature | -10°C to 50°C (14°F to 122°F) |
| Storage Temperature | -20°C to 60°C (-4°F to 140°F) |
| Humidity | 5% ~ 95% (non-condensing) |
| Static Discharge | ±12 kV (Air discharge), ±8 kV (Direct discharge) |
| Drop | 1.5 m drop to concrete |
| Sealing | IP54 |

Certificates

FCC Part15 Class B, CE EMC Class B, CCC

Test condition:

Code39, Data length=3bytes,Minimum space width=10mil, Width ratio=2.5:1, PCS=0.8, Barcode height=11mm,

Testing distance=120mm,Envirmenttemperature =23°C, Envirment light Illumination = 200 LUX

Overview

Left View

The picture below is the left view of HR15 scanner.

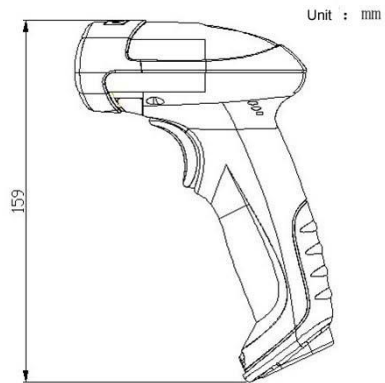

Front View

The picture below is the front view of HR15 scanner.

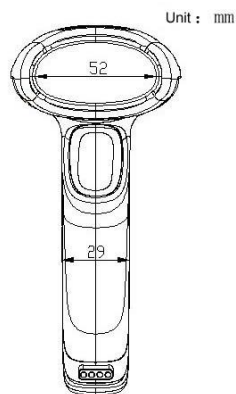

Vertical View

The picture below is the vertical view of HR15 scanner.

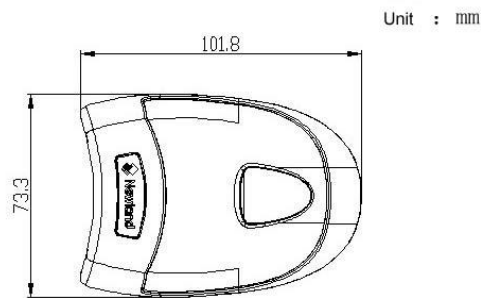

Barcode Reading

- ✧ Make sure the scanner, data cable and power are properly connected before turn on the power.
- ✧ Pressing the trigger to activate the illumination light, then the red illuminating line will appear.
- ✧ For the same batch of barcode, the scanner will keep a very high success ratio in certain distance, which can be regarded as the optimal scanning distance.
- ✧ When the scanner respond with a beep and the red illuminating line goes off, it means the barcode reading is successful, and the scanner will send the data to the host.

Note: For the same batch of barcode, the scanner will keep a very high success ratio in certain distance, which can be regarded as the optimal scanning distance.

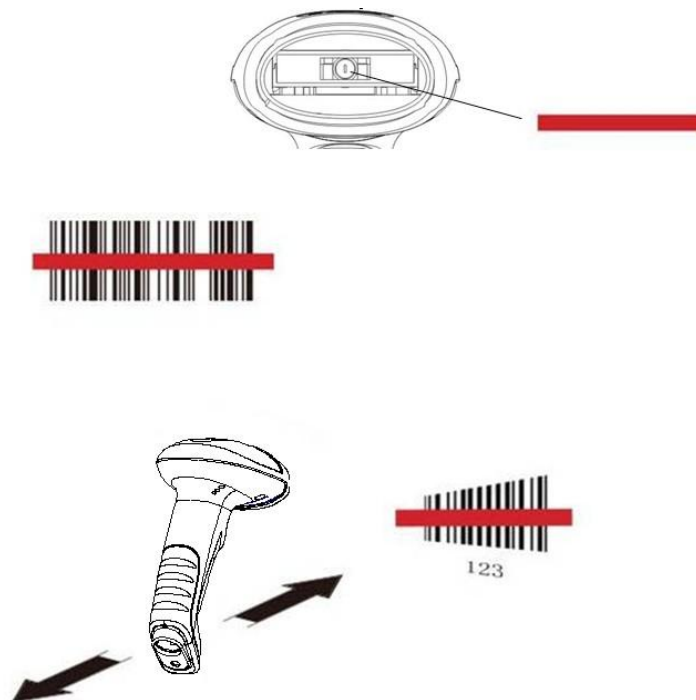



99900031

【Start Setup】

Chapter 2 General Configuration

Introduction

There are two ways to setup the barcode engine.

Setting Barcode

To used reading a series of special barcode to setting the barcode engine. In the following sections, we will introduce the available set of options and features and provide a corresponding setting code.

Setting Command

To used PC to send the setting command string to setting the barcode engine. In the following chapters, in addition to setting code, we will introduce the setting of the command string.

Notice: All the setting command will keep in barcode engine except a few temporary setting commands will disappear after reboot or power off.

Format of Setup Barcode

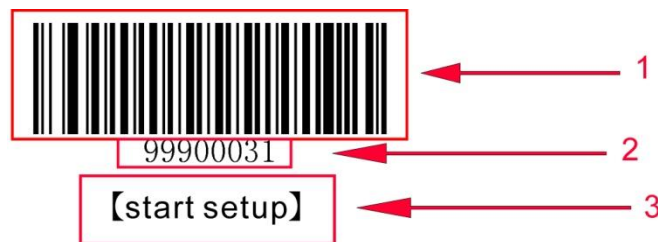

This is the sample of setup barcode.

The setup barcode label is consisted of three parts:

- 1、 The barcode portion of the setup barcode.
- 2、 The command description or code string of corresponding to the setup barcode.
- 3、 The name of the setup barcode or function, such as the function of turn off setup code.



99900032

【Exit Setup】



99900031

【Start Setup】

Use the Setting Barcodes

- ✧ The setup function will be activated by reading the “Start Setup” barcode. The procedure of configuring can be done by reading more than one setup barcodes.
- ✧ If any item or function needs more parameters, such as check byte, please see the last section in this chapter.
- ✧ The current setting command can be send to the host. According to the factory default setting is not able to send the current setting command to the host. By scanning the barcode: “Send the setting command”, the scanner will enable the function to send the setting command to the host.
- ✧ The start setup function is activated in the factory default setting. Only a small possibility that the data barcode is the same with the setting command, thus, it is not necessary to scan the “Exit Setup” barcode to close the setup mode, to keep it will not effect the normal operation.
- ✧ Some functions may adjust the working parameters; the numeric system of parameter is decimal or hexadecimal, these values are entered by setting barcodes. The data code in the appendix includes all the necessary numerical values.
- ✧ In the default mode, the scanner will not send the current setting command to the host; in case of a special need, the customer can set the scanner to send the setting command to the host. The function of setup will not be affected whether the setting command are sending or not. But the setup of “Send the setting command” is only temporarily effective; the scanner will restore to the state of “do not send the setting command” after reboot or power-off.



99900034

【Send the SettingCommand】



99900033

【Do not Send the SettingCommand】

Use the Setup Command

The setup command is based on the communication serial port; it is meant to use the visible characters from 0x20 to 0x7D to describe all the content.

Setup State

When the function setup is carried out through serial communication mode, the device must be set into the “setup state”; in such state, the device only accept, process and respond the command from serial communication.

By sending a specified command can let the device enter to the set state. In the setup state to sending the specified command also allows to exit, the device will self exit from the setup state within 5 seconds did not received any new



99900032

【Exit Setup】



99900031

【Start Setup】

SetupProcess Flow

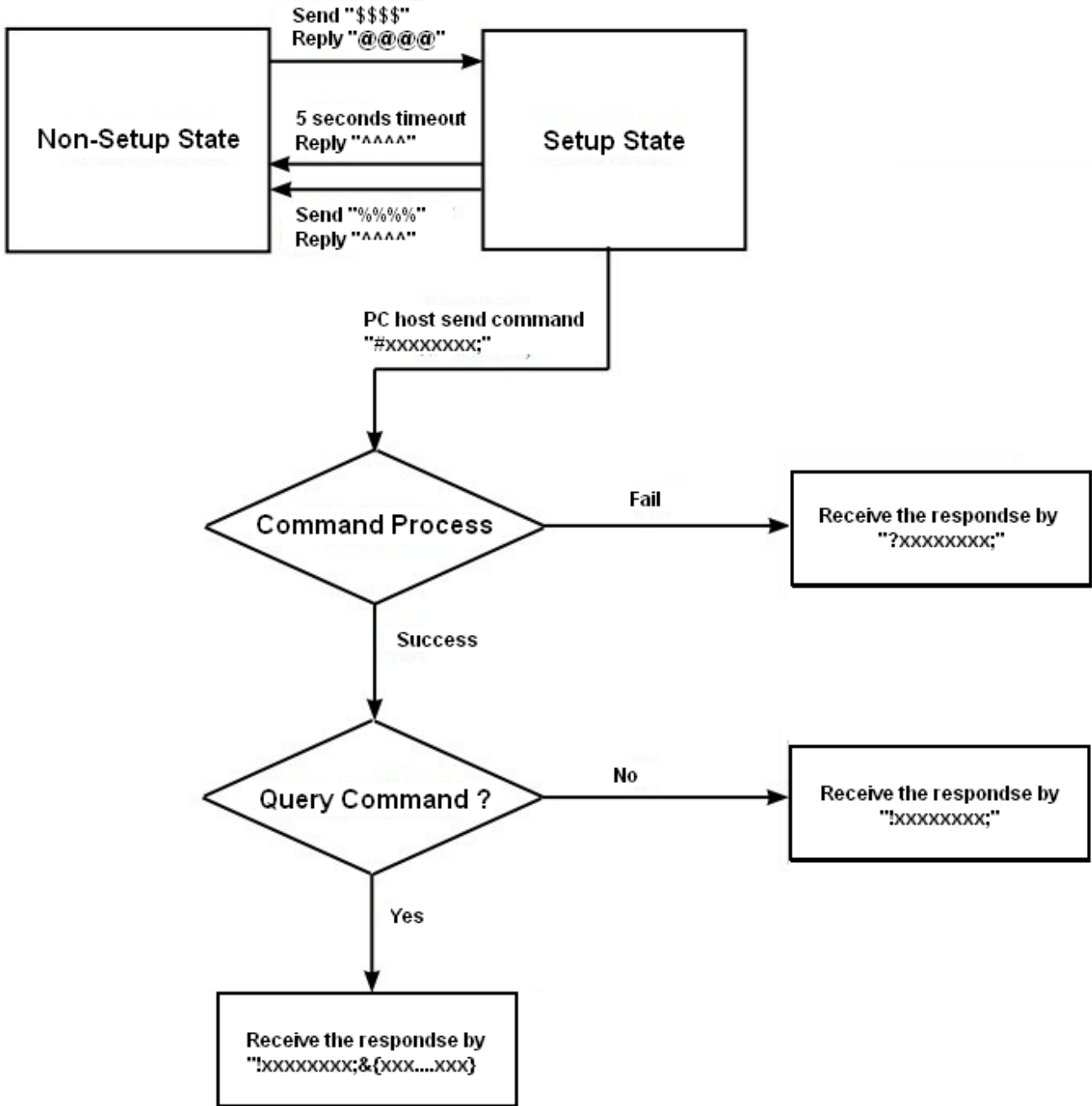

99900032

【Exit Setup】



99900031

【Start Setup】

Default Setup

Factory Default Setting

All the scanners have the factory default setting, by reading the “Restore to Factory Default” barcode, the scanner will restore the factory default.



99900030

【Restore to Factory Default】

Work Mode Selection



99900100

【Power Off】



99900104

【Reboot】



99900103

【Test mode】

Note:

1. Wake up the scanner please pressing trigger.
2. The work mode is a temporarily setting, the device will restore to the previous mode after reboot or power off.

Reading Mode

Manual Scanning Mode

Default setting, the scanner will begin to read the barcode after the trigger is pressed, it will stop after successful reading or if the trigger is loosed.



99900032

【Exit Setup】



99900031

【Start Setup】



99900110

【Manual Scanning】

The scanner can set the reading time in the manual scanning mode.



99900150

【Set the Reading Time】

Note: In the manual scanning mode, the unit of barcode scanning time is 1 second. The parameter range from 0 to15 second. 0 means continue scan.

Auto Scanning Mode

Press the trigger after setup, the scanner will automatically startthe next scan after finish a successful reading; the scanner will stop until the trigger is pressed again. In the default mode, it is not allowed to repeatedly read the same barcode.



99900111

【Auto Scanning Mode】

In the auto scanning mode, the unit of barcode scanning time is 1 second. The parameter range from 0 to15 second. 0 means continue scan. It is also can set to allowed to scanning barcode repeatedly.



99900150

【Set Barcode Reading Time】



99900155

【Not allowed to read the same barcode repeatedly】



99900156

【Allowed to read the same barcode repeatedly】



99900157

【Recounting after the read】

◇ **Allowed to Read the Same Barcode Repeatedly**

The scanner will begin the next barcode reading automatically after successful reading, until the scanner trigger is pressed again.

◇ **Not Allowed to Read the Same Barcode Repeatedly**



99900032

【Exit Setup】



99900031

【Start Setup】

The scanner will begin the next barcode reading automatically after a successful reading, if the next barcode is same with last one, the scanner will discard the barcode, and waiting for the next different barcode. This setting can be stop when the scanner trigger be pressed again.

◇ **Recounting After Successful Reading**

Setup the scanner recount the reading timer after successful a barcode reading.

Intermittent Reading Mode

Device will intermittent reading the barcode. Whether reading successful or not, the reading twice intervals are fixed, intermittent time default value is 1sec, this value can be change. The length of reading time is fixed on 100 ms.



99900112

【Intermittent Reading】



99900151

【Set the Scanning Time Interval】

Note: The time interval is counted in units of 500ms, which can be set in 15 levels (from 01-15). For example

Example:

The steps of set the time interval to 5000ms.

1. Read the “Start Setup” barcode.
2. Read the “Set the Scanning Time Interval” barcode.
3. Read the numeric “1” and ‘0” barcode.
4. Read the “Exit Setup” barcode.

Sense Reading Mode

The device do not need to trigger the scan, and will auto detecting the scan environment changed to start to reading. The reading finished, device will turn to monitoring state to waiting for the next changes in the environment. The surrounding environment sensor sensitivity can be setup. During this mode, click the trigger button can also start reading..



99900113

【Sense Reading】



99900032

【Exit Setup】



99900031

【Start Setup】

In the sensing reading mode, the scanner can set the reading time. in the unit of 1 second, the parameter ranges from 0-15sec, 0 means non-stop. The scanner also can set the time interval in the interval reading mode (stable sensing reading time). Interval time is in the unit of 500ms, which can be set in 15 levels (from 01-15).



99900150

【Set the Barcode Reading Time】



99900151

【Set the Scanning Time Intervals】

The customer can select the sensivity according to the environmrnt, in order to increase the reading efficiency.



99900152

【High Sensitivity】



99900154

【Low Sensitivity】



99900153

【Medium Sensitivity】



99900161

【Custom Sensitivity】

Sensitivity Setup in the Sense Mode

It can be set in 16 levels from 0 to F, the samller the value, the higher the sensibility.

Example:

The steps of set the sensibility to level 5.

1. Read the “Start Setup”barcode.
2. Read the “Custom Sensibility” barcode.
3. Read the numeric “5” barcode.
4. Read the “Exit Setup” barcode.

Continuous Reading Mode

The device going to continuous reading without triggered. After successful barcode reading, the scanner will become standby, and keep doing same loop.



99900032

【Exit Setup】



99900031

【Start Setup】



99900114

【Continuous Reading】

The scanner can set the time interval of scanning in the continuous reading mode.



99900151

【Time Interval of Scanning】

Note : In the continuous reading mode, the time interval of scanning is in unit of 500ms, the parameter ranges from 0 to 7500ms

Extended Sense Reading Mode

The device will to check the environmental change in front of the scanning window. It will delay 200ms before the scanner begin to read. After reading the barcode, the scanner will stop and stay in the checking mode, waiting for the next environment change.



99900115

【Extended Sense Reading】

In the extended sense reading mode, the scanner can set the barcode reading time and the time intervals.



99900150

【Set the Barcode Reading Time】



99900151

【Set the Scanning Time Intervals】

In the extended sense reading mode, the barcode reading time takes 2sec as the unit, the parameter range is 0-30sec, 0 means non-stop. The time interval takes 200ms as the unit, the parameter ranges from 0 to 300ms.

Command Triggered Reading Mode

After setup, to begin triggered scanning by sending the stop command in the terminal (such as PC) or reading the “Begin Simulating Trigger”. If scanning is successful, then the data will be sent back. The scanner will stop automatically. If it is not successful, the scanner will keep scanning, until the command of stop scanning is received.

To stop barcode scanning by sending the stop command in the terminal (such as PC) or reading the “Stop Simulating Trigger”, and require a 2-Digit character passback (such as 0A,0X,etc.,)



99900032

【Exit Setup】



99900031

【Start Setup】

【Begin Simulating Trigger】



99900036

【Stop Simulating Trigger】



99900116

【Command Triggered Scanning】

If the reading fails, the scanner will send a symbol to describe that the reading is not successful. Customer can set this symbol.



99904200

【Set the Character to Describe Unsuccessful Reading】

Security Level Setup

This value indicates the number of times to decode before correct reading of the confirmation code, the higher value indicated the wrong decoded rate is lower and slower decode speed, on the contrary, faster the decode speed.



99900120

【Set Security Level to 1】



99900122

【Set Security Level to 3】



99900121

【Set Security Level to 2】



99900123

【Set Security Level to 4】

Decoding Sound Setup



99900130

【Turn off Decoding Audio】



99900136

【Intermediate Frequency - Weak】



99900032

【Exit Setup】



99900031

【Start Setup】

【High Frequency - Loud】



99900137

【Low Frequency - Loud】



99900132

【High Frequency - Median】



99900141

【Low Frequency - Weak】



99900133

【High Frequency - Weak】



99900142

【150ms Sound Length】



99900134

【Intermediate Frequency - Loud】



99900143

【100ms Sound Length】



99900135

【Intermediate Frequency - Median】



99900144

【50ms Sound Length】

Other Setup

Activate/Abort Temporary Mute



99900040

【Active Temporary Mute】



99900041

【Exit Temporary Mute】



99900032

【Exit Setup】



99900031

【Start Setup】

Chapter 3 Inquiry Command

Introduction

In order to inquire, the HR15 cradle information can feed back to the host by reading the setup barcode.



99900300

【Inquire all the Information】



99900303

【Inquire the Release Date】



99900301

【Inquire the Firmware Information】



99900304

【Inquire the Product Name】



99900302

【Inquire the Serial Number】



99900032

【Exit Setup】



Chapter 4 Communication Setup

Serial Port Setup

Baud Rate Setup

When the scanner connects with host by serial port, both sides should set the same parameters in order to guarantee the smooth communication, the baud rate (transmission speed) of communication is necessary.





99900031

【Start Setup】

Check Setup



99902120

【No Check】



99902122

【Even Check】



99902121

【Odd Check】

Stop Bit



99902131

【1 Stop Bit】



99902133

【2 Stop bits】

Flow Control Setup



99902140

No Flow Control



99902142

CTS Flow Control



99902141

RTS Flow Control



99902143

RTS_CTS Flow Control

Data Bit



99902150

8 Data Bits



99902163



99900032

【Exit Setup】



99900031

【Start Setup】



99902160

8 Data Bits, no Check, 1 Stop Bit



99902161

8 Data Bits, Even Check, 1 Stop Bit



99902162

8 Data Bits, Odd Check, 1 Stop Bit



99902151

7 Data Bits



99902166

7 Data Bits, Even Check, 1 Stop Bit

8 Data Bits, no Check, 2 Stop Bit



99902164

8 Data Bits, Even Check, 2 Stop Bit



99902165

8 Data Bits, Odd Check, 2 Stop Bit



99902167

7 Data Bits, Even Check, 2 Stop Bit



99902170

7 Data Bits, Odd Check, 2 Stop Bit



99902171

7 Data Bits, Odd Check, 2 Stop Bit

USB Function Setup

USB Virtual Keyboard Function



99902300

USB Virtual Keyboard Function



99900032

【Exit Setup】



99900031

【Start Setup】

USB Virtual Serial Port Function



99902301

USB Virtual Serial Port Function



99900032

【Exit Setup】



99900031

【Start Setup】

Keyboard Function Setup

Keyboard Layout



99902201

1st American English



99902202

2nd Japanese



99902203

3rd Danish



99902204

4th Finland



99902205

5th France



99902206

6th Turkey F



99902207

7th Italy



99902210

8th Norway



99902211

9th Spanish



99902212

10th Turkey Q



99902213

11st Britain

Set the Delay between Characters

The range of the delay time between characters is from 0 to 75 ms, it takes 5ms as one level, totally 15 levels. The default value is 0ms.



99900032

【Exit Setup】



99900031

【Start Setup】



99902220

Delay Setup Between Characters

Character Conversion



99902230

No Conversion



99902231

All Capital Letter



99902232

All Lowercase Letter



99902233

Case the Opposite



99900032

【Exit Setup】



99900031
【Start Setup】

Chapter 5 Data Format Setup

Introduction

After successful barcode reading, the customer will receive a string of data which can be numbers, English characters symbols and so on, this string of data is the data information included in the barcode.

The barcode data information may not be enough in the application, or the data included in the barcode can not meet your requirement. If you want to know from which type of barcode comes out this string of data, or in which date the barcode data is scanned, or you hope that the text in which the barcode is recorded can perform automatical change lines after one barcode scanning is finished, but these information may not be included in the barcode data.

Adding these information into the barcode will increase the barcode length and make it unflexible, thus, this method does not deserve recommendation. Then we thought about to add something before or after the barcode data, which can be added or shielded according to the requirement. The things we add are the prefix and suffix of barcode data. This method can help to meet the requirement and it is not necessary to change the barcode.

Note: the barcode processing step: to add prefix and suffix first (except for the end mark suffix), then the end mark suffix.

Prefix Sequence Setup



CodeID+Custom+AIMID



Custom+CodeID+AIMID

Custom Prefix

Add Custom Prefix or Not

The custom prefix will add the customer-defined character string before the decoding information, the length of character string should not more than 10.

For example, it is allowed to add custom prefix and set the prefix to character string "AB", by reading the barcode with data "123", the scanner adds "AB" before "123", and the host will receive "AB123".



99900032
【Exit Setup】



99900031
【Start Setup】

It is not Allow to Add Custom Prefix



99904021

Allow to Add Custom Prefix

Define the Custom Prefix

Read the “Set the Custom Prefix” first, and then read the hexadecimal value of every byte of the prefix character string which will be set according to priority.



99904022

Set custom prefixes

For example: set the custome prefix to “CODE” (the hexadecimal value is 0x43/0x4F/0x44/0x45)

1. Read the “Start Setup” barcode.
2. Read the ”Set the Custom Prefix” barcode.
3. Read the following number code: “4”, “3”, “4”, “F”, “4”, “4”, “4”, “5”
4. Read the “Save” barcode.
5. Read the “Exit Setup”barcode.

After the setup of “it is allowed to add custom profix”is finished, by reading any barcode, the scanner will add custom prefix character string “CODE” before the data.

AIM ID Prefix

AIM is abbreviation of”Automatic Identification Manufacturers”, AIMID defines the identifier for every kind of standard barcode, see the appendix. After decoding, the scanner can add the identifier before the barcode data, which can be regarded as AIMID prefix.



99904030

It is not Allow to Add AIMID Prefix



99904031

Allow to Add AIMID Prefix

Code ID Prefix

Except for using AIM prefix to identify different barcode, the customers also can use CodeID prefix to perform the same function. Different from the AIM prefix, the customer can define the Codelid prefix corresponding to every kind of barcode.

The CodeID of all the barcodes includes one or two characters, which must be alphabet and can not be set as



99900032
【Exit Setup】



99900031

【Start Setup】

numbers, invisible character or interpunction.



99904040

It is not Allow to Add CodeID Prefix



99904042

Restore the Default CodeID



99904041

Allow to Add CodeID Prefix

Custom Suffix

Add Custom suffix or Not

The custom suffix will add the customer-defined character string after the decoding information.

For example, it is allowed to add custom suffix and set the suffix to character string "AB", by reading the barcode with data "123", the scanner adds "AB" after "123, and the host will receive "AB123"



99904100

It is not Allow to Add Custom Suffix



99904101

Allow to Add Custom Suffix

Define the Custom suffix

Read the "Set the Custom suffix" first, and then read the hexadecimal value of every byte of the suffix character string which will be set, according to priority.



99904102

Set the Custom suffix

For example: Set the custome suffix to "AGE" (the hexadecimal value is 0x41/0x47/0x45)

1. Read the "Start Setup" barcode.
2. Read the "Set the Custom Suffix" barcode.
3. Read the following number code: "4" "1" "4" "7" "4" "5"
4. Read the "Save" barcode.
5. Read the "Exit Setup" barcode.



99900032

【Exit Setup】



99900031
【Start Setup】

After the setup of “it is allowed to add custom suffix” is finished, by reading any barcode, the scanner will add custom suffix character string “AGE” after the data.

End Mark Suffix

Add End Mark Suffix or Not

End mark suffix is used to declare the end of a intact data information, which must be the last part of the data, no other data will be added behind it.

The content, decoding information and prefix of custom suffix can be formatted, but the end mark suffix can not, and this is the fundamental differences between end mark suffix and custom suffix.



99904110

It is not Allow to Add End Mark Suffix



99904111

Allow to Add End Mark Suffix

Define the End Mark Suffix

Read the “Define the End Mark Suffix” first, and then read the hexadecimal value of every byte of the suffix character string which will be set, according to priority.



99904112

Set the End Mark Suffix



99904113

Set the end mark suffix to 0x0D, ,and make it can be sent



99904114

Set the end mark suffix to 0x0D,0x0A ,and make it can be sent

For Example: Set the end mark of Windows Operation System to “newline”

1. Read the “Start Setup” barcode.
2. Read the “Set the End Mark Suffix” barcode.
3. Read the “Set the end mark suffix to 0x0D,0x0A ,and make it can be sent”.
4. Read the “Save” barcode.
5. Read the “Exit Setup” barcode.



99900032
【Exit Setup】



99900031

【Start Setup】

After setup of "it is allowed to add end mark suffix" is finished, by reading any barcode, the scanner will add newline after the final data.



99900032

【Exit Setup】



99900031
【Start Setup】

Chapter 6 Barcode Parameter Setup

Introduction

Every kind of barcode has its own special character; the customer can adjust the scanner to suit the character changes by the setup barcode introduced in this chapter. The customer can also forbid the scanner to read the barcode types which are not used in order to enhance its working performance.

Code 128

Restore Default Value

By reading the barcode, the parameter setup of Code 128 will be restored to the factory default state.



Restore the Default Setup Value of Code 128

Allow to Read Code 128 or not



Allow to Read Code 128



Prohibit Reading Code 128

Note:the scanner will become unable to read Code 128 by reading the setup barcode “Prohibit Reading Code 128”, thus, if the scanner is unable to read the Code128, please try to read the setuo barcode “allow to read code 128”.

Code ID Setup

To activate the setup function by reading “CodeID setup”, then read the hexadcimal value inaccordance with the character which will be set to the CodeID.



CodeID Setup



99900032
【Exit Setup】



99900031

【Start Setup】

Example: Set the CodeID of Code 128 to “p” (the hexadecimal value is 0x70):

1. Read the “Start Setup” barcode.
2. Read the “CodeID Setup” barcode.
3. Read the numeric barcode “7”, “0” (see the appendix—numeric barcode)
4. Read the “Save” (see the appendix—numeric barcode)
5. Read the “Exit Setup” barcode.

Set the Barcode Reading Length Limit

The scanner is only able to read the Code 128 with transmission content length falls in the limited range, the range is consisted of the maximum value and minimum value in units of byte (the maximum value and minimum value also included), the Code 128 exceeds the range can not be read or transmitted.

- ◇ Read the barcode of “Set the Minimum Length Limit” to adjust the minimum length limit
- ◇ Read the barcode of “Set the Maximum Length Limit” to adjust the maximum length limit



99910003

Set the Minimum Length Limit



99910004

Set the Maximum Length Limit

Note :the maximum length limit of any 1D barcode must not exceed 255, if the maximum length is shorter than the minimum length, then the scanner is only able to read the barcodes with the minimum length and the the maximum length; if the maximum length equals to the minimum length, then the scanner is only able to read the barcode with such length.

Example: Set the scanner read the Code128 with barcode length between 8 to 12 characters.

1. Read the “Stat Setup” barcode.
2. Read the barcode of “Set the Minimum Length Limit”.
3. Read the numeric barcode “8”, (see the appendix—numeric barcode)
4. Read the “Save” barcode.(see the appendix—numeric barcode)
5. Read the barcode of “Set the Maximum Length Limit”.
6. Read the numeric barcode “1”.
7. Read the numeric barcode “2”.
8. Read the “Save” barcode.(see the appendix—numeric barcode)
9. Read the “Exit Setup” barcode.



99900032

【Exit Setup】



99900031
【Start Setup】

UCC/EAN-128

Restore Default Value

By reading the barcode, the parameter setup of UCC/EAN-128 will be restored to the factory default state.



99910100

Restore the Default Setup Value of UCC/EAN-128

Allow to Read UCC/EAN-128 or not



99910102

Allow to Read UCC/EAN-128



99910101

Prohibit Reading UCC/EAN-128

Note: the scanner will become unable to read UCC/EAN-128 by reading the setup barcode “Prohibit Reading UCC/EAN-128”, thus, if the scanner is unable to read the UCC/EAN-128, please try to read the setup barcode “allow to read UCC/EAN-128”.

Code ID Setup

To activate the setup function by reading “CodeID setup”, then read the hexadecimal value in accordance with the character which will be set to the CodeID.



99910105

CodeID Setup

Example: Set the CodeID of UCC/EAN-128 to “p” (the hexadecimal value is 0x70):

1. Read the “Start Setup” barcode.
2. Read the “CodeID Setup” barcode.
3. Read the numeric barcode “7”, “0” (see the appendix—numeric barcode)
4. Read the “Save” barcode.(see the appendix—numeric barcode)
5. Read the “Exit Setup” barcode.

Set the Barcode Reading Length

The scanner is only able to read the UCC/EAN-128 whose transmission content length is in the limited range, the range is consisted of the maximum value and minimum value in units of character (the maximum value and minimum value also included), The UCC/EAN-128 exceeds the range can not be read or transmitted.



99900032
【Exit Setup】



99900031

【Start Setup】

- ◇ Read the barcode of “Set the Minimum Length Limit” to adjust the minimum length limit
- ◇ Read the barcode of “Set the Maximum Length Limit” to adjust the maximum length limit



99910103

Set the Maximum Length Limi



99910104

Set the Minimum Length Limit

Note : the maximum length limit of any 1D barcode must not exceed 255, if the maximum length is shorter than the minimum length, then the scanner is only able to read the barcodes with the minimum length and the the maximum length; if the maximum length equals to the minimum length, then the scanner is only able to read the barcode with such length.

Example: Set the scannerread the UCC/EAN-128 with barcode length between 8 to 12 characters.

1. Read the “Start Setup” barcode.
2. Read the barcode of “Set the Minimum Length Limit”.
3. Read the numeric barcode “8”, (see the appendix—numeric barcode)
4. Read the “Save” barcode. (see the appendix—numeric barcode)
5. Read the barcode of “Set the Maximum Length Limit”.
6. Read the numeric barcode “1”.
7. Read the numeric barcode “2”.
8. Read the “Save” barcode.(see the appendix—numeric barcode)
9. Read the “Exit Setup” barcode.

AIM 128

Restore Default Value

By reading the barcode, the parameter setup of UCC/EAN-128 will be restored to the factory default state.



99910200

Restore the Default Setup Value of UCC/EAN-128

AIM 128 Allow to Read AIM-128 or not



99910202

Allow to Read AIM-128



99910201

Prohibit Reading AIM-128

Note:the scanner will become unable to read AIM-128 by reading the setup barcode “Prohibit Reading AIM-128”, thus, if the scanner is unable to read the AIM-128, please try to read the setuo barcode “allow to read AIM-128”.



99900032

【Exit Setup】



99900031
【Start Setup】

Code ID Setup

To activate the setup function by reading “CodeID setup”, then read the hexadecimal value in accordance with the character which will be set to the CodeID.



CodeID Setup

Example: Set the CodeID of AIM-128 to “p” (the hexadecimal value is 0x70):

1. Read the “Start Setup” barcode.
2. Read the “CodeID Setup” barcode.
3. Read the numeric barcode “7”, “0” (see the appendix—numeric barcode)
4. Read the “Save” barcode.(see the appendix—numeric barcode)
5. Read the “Exit Setup” barcode.

Set the Barcode Reading Length

The scanner is only able to read the AIM-128 whose transmission content length is in the limited range, the range is consisted of the maximum value and minimum value in units of character (the maximum value and minimum value also included), The AIM-128 exceeds the range can not be read or transmitted.

- ◇ Read the barcode of “Set the Minimum Length Limit” to adjust the minimum length limit.
- ◇ Read the barcode of “Set the Maximum Length Limit” to adjust the maximum length limit



Set the Maximum Length Limit



Set the Minimum Length Limit

Note : the maximum length limit of any 1D barcode must not exceed 255, if the maximum length is shorter than the minimum length, then the scanner is only able to read the barcodes with the minimum length and the the maximum length; if the maximum length equals to the minimum length, then the scanner is only able to read the barcode with such length

Example: Set the scanner read the AIM128 with barcode length between 8 to 12 characters.

1. Read the “Start Setup” barcode.
2. Read the barcode of “Set the Minimum Length Limit”.
3. Read the numeric barcode “8”, (see the appendix—numeric barcode)
4. Read the ‘Save” barcode.(see the appendix—numeric barcode)
5. Read the barcode of “Set the Maximum Length Limit”
6. Read the numeric barcode “1”.
7. Read the numeric barcode “2”.



99900032
【Exit Setup】



99900031

【Start Setup】

8. Read the ‘Save’ barcode.(see the appendix—numeric barcode)
9. Read the “Exit Setup” barcode.

EAN-8

Restore Default Value

By reading the barcode, the parameter setup of EAN-8 will be restored to the factory default state.



99910400

Restore the Default Setup Value of EAN-8

Allow to Read EAN-8 or not



99910402

Allow to Read EAN-8



99910401

Prohibit Reading EAN-8

Note:the scanner will become unable to read EAN-8 by reading the setup barcode “Prohibit Reading EAN-8”, thus, if the scanner is unable to read the EAN-8, please try to read the setuo barcode “allow to read EAN-8”.

Code ID Setup

To activate the setup function by reading “CodeID setup”, then read the hexadecimal value inaccordance with the character which will be set to the CodeID.



99910416

CodeID Setup

Example: Set the CodeID of EAN-8 to “p” (the hexadecimal value is 0x70).

1. Read the “Start Setup” barcode.
2. Read the “CodeID Setup” barcode.
3. Read the numeric barcode “7”, “0” (see the appendix—numeric barcode)
4. Read the “Save” barcode.(see the appendix—numeric barcode)
5. Read the “Exit Setup” barcode.

Set Whether or not to Read 2-Digit Extracode

2-Digit extended code means to add 2-digit numeric barcode behind the normal barcode.



99900032

【Exit Setup】



99900031

【Start Setup】



99910405

Do not read the 2-Digit Extracode



99910406

Allow to Read 2-Digit Extracode



99910407

The Barcode Must Include 2-Digit Extracode,

Set Whether or not to Read 5-Digit Extracode

5-Digit extended code means to add 5-Digit numeric barcode behind the normal barcode.



99910410

Do not read the 5-Digit Extracode



99910411

Allow to Read 5- Digit Extracode



99910412

The Barcode Must Include 5-Digit Extracode

Note:

- ◇ By setting “Allow to Read 2-Digit Extracode”, the scanner can read the new barcode consisted of normal barcode and extracode, and the normal barcode without extracode.
- ◇ By setting “Do not read the 2-Digit Extracode”, the scanner can only read the normal barcode part of the new barcode, the additional part of the new barcode which combines the normal barcode and extended barcode can not be read.
- ◇ By setting “The Barcode Must Include 2-Digit Extracode”, the scanner is only able to read the 2-digits extracode.

Set Whether or not to Send the Check Digit

The barcode data of EAN-8 is fixed in 8 characters, the 8th digit is the check digit for checking the correctness of the 8 characters.



99910404

Transmit the Check Bit



99910403

Do not Transmit the Check Digit



99900032

【Exit Setup】



99900031
【Start Setup】

EAN-13

Restore Default Value

By reading the barcode, the parameter setup of EAN-13 will be restored to the factory default state.



99910500

Restore the Default Setup Value of EAN-13

Allow to Read EAN-13 or not



99910502

Allow to Read EAN-13



99910501

Prohibit Reading EAN-13

Note:the scanner will become unable to read EAN-13 by reading the setup barcode “Prohibit Reading EAN-13”, thus, if the scanner is unable to read the EAN-13, please try to read the setuo barcode “allow to read EAN-13”.

Set Whether or not to Send the Check Digit

The data of EAN-13 barcode is fixed 13 digit, the 13rd bit is the check bit which is used in checking the correctness of all the 13 digit.



99910504

Send the Check Digit



99910503

Send the Check Digit

Code IDSetup

To activate the setup function by reading “CodeID Setup”, then read and save the hexadcimal value in accordance with the character which will be set to the CodeID.



99910513

CodeID Setup

Example: Set the CodeID of EAN-13 to “p” (the hexadcimal value is 0x70).

1. Read the “Start Setup” barcode.
2. Read the “CodeID Setup” barcode.
3. Read the numeric barcode “7”, “0” (see the appendix—numeric barcode)



99900032
【Exit Setup】



99900031

【Start Setup】

4. Read the “Save” barcode.(see the appendix—numeric barcode)
5. Read the “Exit Setup” barcode.

Set Whether or not to Read 2-Digit Extracode

2-Digit extended code means to add 2-digit numeric barcode behind the normal barcode.



99910505

Do not read the 2-Digit Extracode



99910506

Allow to Read 2-Digit Extracode



99910507

The Barcode Must Include 2-Digit Extracode

Set Whether or not to Read 5-Digit Extracode

5-Digit extended code means to add 5-Digit numeric barcode behind the normal barcode.



99910510

Do not read the 5-Digit Extracode



99910511

Allow to Read 5-Digit Extracode



99910512

The Barcode Must Include 5-Digit Extracode

Note:

- ◇ By setting “Allow to Read 2-Digit Extracode”, the scanner can read the new barcode consisted of normal barcode and extracode, and the normal barcode without extracode.
- ◇ By setting “Do not read the 2-Digit Extracode”, the scanner can only read the normal barcode part of the new barcode, the additional part of the new barcode which combines the normal barcode and extended barcode can not be read.
- ◇ By setting “The Barcode Must Include 2-Digit Extracode”,the scanner is only able to read the 2-digits extracode.

Extended Setup

- ◇ Do not extend the barcode into 13-digit EAN-13, means to keep the original type and data length.
- ◇ Extend the Barcode into 13-Digits EAN-13, and lead by 0, means extend the data length but keep the barcode type



99900032

【Exit Setup】



99900031

【Start Setup】

unchanged.

- ◇ Extend the Barcode and Transfer into EAN-13, means extend the barcode type and data length.



99910413

Do not Extend the Barcode into 13-Digit EAN-13



99910414

Extend the Barcode into 13-Digit EAN-13, and lead by 0



99910415

Extend the Barcode and Transfer into EAN-13

ISSN

Restore Default Value

By reading the barcode, the parameter setup of ISSN will be restored to the factory default state.



99910600

Restore the Default Setup Value of ISSN

Allow to Read ISSN or not



99910602

Allow to Read ISSN



99910601

Prohibit Reading ISSN

CodeID Setup

To activate the setup function by reading “CodeID setup”, then read and save the hexadecimal value in accordance with the character which will be set to the CodeID.



99910603

CodeID Setup

Example: Set the CodeID of ISSN to “p” (the hexadecimal value is 0x70).

1. Read the “Start Setup” barcode.
2. Read the “CodeID Setup” barcode.



99900032

【Exit Setup】



99900031

【Start Setup】

3. Read the numeric barcode “7”, “0” (see the appendix—numeric barcode)
4. Read the “Save” barcode.(see the appendix—numeric barcode)
5. Read the “Exit Setup” barcode.

ISBN

Restore Default Value

By reading the barcode, the parameter setup of ISBN will be restored to the factory default state.



99910700

Restore the Default Setup Value of ISSN

Allow to Read ISBN or not



99910702

Allow to Read ISBN



99910701

Prohibit Reading ISBN

Note:the scanner will become unable to read ISBN by reading the setup barcode “Prohibit Reading ISBN”, thus, if the scanner is unable to read the ISBN, please try to read the setuo barcode “allow to read ISBN”.

ISBN Data Length Setup



99910704

Adopt 13 Characters



99910703

Adopt 10 Characters

CodeIDSetup

To activate the setup function by reading “CodeID setup”, then read and save the hexadcimal value in accordance with the character which will be set to the CodeID.



99910705

CodeID Setup

Example: Set the CodeID of ISBN to “p” (the hexadcimal value is 0x70).

1. Read the “Start Setup” barcode.
2. Read the “CodeID Setup” barcode.



99900032

【Exit Setup】



99900031

【Start Setup】

3. Read the numeric barcode “7”, “0” (see the appendix—numeric barcode)
4. Read the “Save” barcode.(see the appendix—numeric barcode)
5. Read the “Exit Setup” barcode.

UPC-E

Restore Default Value

By reading the barcode, the parameter setup of UPC-E will be restored to the factory default state.



99911000

Restore the Default Setup Value of UPC-E

Allow to Read UPC-E or not



99911002

Allow to Read UPC-E



99911001

Prohibit Reading UPC-E

Note:the scanner will become unable to read UPC-E by reading the setup barcode “Prohibit Reading UPC-E”, thus, if the scanner is unable to read the UPC-E, please try to read the setuo barcode “allow to read UPC-E”.

Set Whether or not to Send the Check Digit

The data of UPC-E barcode is fixed 8 digit, the 8st bit is the check bit which is used in checking the correctness of alll the 8 digit.



99911004

Send the Check Digit



99911003

Do not Send the Check Digit

CodeID Setup

To activate the setup function by reading “CodeID setup”, then read and save the hexadcimal value inaccordance with the character which will be set to the CodeID.



99911020



99900032

【Exit Setup】



99900031

【Start Setup】

CodeID Setup

Example: Set the CodeID of UPC-Eto “p” (the hexadecimal value is 0x70).

1. Read the “Start Setup” barcode.
2. Read the “CodeID Setup” barcode.
3. Read the numeric barcode “7”, “0” (see the appendix—numeric barcode)
4. Read the “Save” barcode.(see the appendix—numeric barcode)
5. Read the “Exit Setup” barcode.

Set Whether or not to Read 2-Digit Extracode

2-Digit extended code means to add 2-Digit numeric barcode behind the normal barcode.



99911005

Do not read the 2-Digit Extracode



99911006

Allow to Read 2-Digit Extracode



99911007

The Barcode Must Include 2-Digit Extracode,

Set Whether or not to Read 5-Digit Extracode

5-Digit extended code means to add 5-Digit numeric barcode behind the normal barcode.



99911010

Do not read the 5-Digit Extracode



99911011

Allow to read the 5-Digit Extracode



99911012

The Barcode Must Include 5-Digit Extracode

Note:

- ◇ By setting “Allow to Read 2-Digit Extracode”, the scanner can read the new barcode consisted of normal barcode and extracode, and the normal barcode without extracode.
- ◇ By setting “Do not read the 2-Digit Extracode”, the scanner can only read the normal barcode part of the new barcode, the additional part of the new barcode which combines the normal barcode and extended barcode can not be read.



99900032

【Exit Setup】



99900031

【Start Setup】

- ◇ By setting “The Barcode Must Include 2-Digit Extracode,the scanner is only able to read the 2-digits extracode.

Set Whether or not to Transmit the System Character “0”

The first character of UPC-E barcode is the system character, the fixed value is “0”.



99911013

Do not Transmit System Character “0”



99911014

Transmit System Character “0”

Extension Setup

- ◇ “Do not Extend the Barcode Information” means keep the original barcode type and data bit,
- ◇ “Extend the Barcode Information into UPC-A” means extend the data bit and leave the barcode type unchanged.
- ◇ “Extend the Barcode Information and Type into UPC-A” means extend the barcode type and data bit.



99911015

Do not Extend the Barcode Information



99911016

Extend the Barcode Information into UPC-A



99911017

Extend the Barcode Information and Type into UPC-A

UPC-A

Restore Default Value

By reading the barcode, the parameter setup of UPC-A will be restored to the factory default state.



Restore the Default Setup Value of UPC-A



99900032

【Exit Setup】



99900031
【Start Setup】

Allow to Read UPC-A or not



99911102
Allow to Read UPC-A



99911101
Prohibit Reading UPC-A

Note:the scanner will become unable to read UPC-A by reading the setup barcode “Prohibit Reading UPC-A”, thus, if the scanner is unable to read the UPC-A, please try to read the setuo barcode “allow to read UPC-A”.

CodeID Setup

To activate the setup function by reading “CodeID setup”, then read the hexadcimal value inaccordance with the character which will be set to the CodeID.



99911115
CodeID Setup

Example: Set the CodeID of UPC-Ato “p” (the hexadcimal value is 0x70).

1. Read the “Start Setup” barcode.
2. Read the “CodeID Setup” barcode.
3. Read the numeric barcode “7”, “0” (see the appendix—numeric barcode)
4. Read the “Save” barcode.(see the appendix—numeric barcode)
5. Read the “Exit Setup” barcode.

Set Whether or not to Transimit the Check Digit

The barcode data of UPC-A is fixed of 13 digit, the 13rd digit is the check digit.



99911104
Send the Check Digit



99911103
Do not Send the Check Digit

Set Whether or not to Transmit the System Digit “0”

The first character of UPC-E barcode is the system Digit, the value is “0”.



99900032
【Exit Setup】



99900031

【Start Setup】

Do not Transmit System Character “0”



99911114

Transmit System Character “0”

Set Whether or not to Read 2-Digit Extracode

2-Digit extended code means to add 2-digit numeric barcode behind the normal barcode.



99911105

Do not read the 2-Digit Extracode



99911106

Allow to Read 2-Digit Extracode



99911107

The Barcode Must Include 2-Digit Extracode

Set Whether or not to Read 5-Digit Extracode

5-Digit extended code means to add 5-digit numeric barcode behind the normal barcode



99911110

Do not read the 5-Digit Extracode



99911111

Allow to Read 5-Digit Extracode



99911112

The Barcode Must Include 5-Digit Extracode

Note:

- ◇ By setting “Allow to Read 2-Digit Extracode”, the scanner can read the new barcode consisted of normal barcode and extracode, and the normal barcode without extracode.
- ◇ By setting “Do not read the 2-Digit Extracode”, the scanner can only read the normal barcode part of the new barcode, the additional part of the new barcode which combines the normal barcode and extended barcode can not be read.
- ◇ By setting “The Barcode Must Include 2-Digit Extracode”, the scanner is only able to read the 2-digit extracode.



99900032

【Exit Setup】



99900031
【Start Setup】

Interleaved 2 of 5

Restore Default Value

By reading the barcode, the parameter setup of Interleaved 2 of 5 will be restored to the factory default state.



Restore the Default Setup Value of Interleaved 2 of 5

Allow to Read Interleaved 2 of 5 or not



Allow to Read Interleaved 2 of 5



Prohibit Reading Interleaved 2 of 5

Note:the scanner will become unable to read Interleaved 2 of 5 by reading the setup barcode “Prohibit Reading Interleaved 2 of 5”, thus, if the scanner is unable to read the Interleaved 2 of 5, please try to read the setup barcode “allow to read Interleaved 2 of 5”.

Code ID Setup

To activate the setup function by reading “CodeID setup”, then read the hexadecimal value in accordance with the character which will be set to the CodeID.



CodeID Setup

Example: Set the CodeID of Interleaved 2 of 5 to “p” (the hexadecimal value is 0x70).

1. Read the “Start Setup” barcode.
2. Read the “CodeID Setup” barcode.
3. Read the numeric barcode “7”, “0” (see the appendix—numeric barcode)
4. Read the “Save” barcode.(see the appendix—numeric barcode)
5. Read the “Exit Setup” barcode.

Set Whether or not to Transmit the Check Character

Interleaved 2 of 5 barcode data does not compulsively include the check digit, if check digit exists, then it is the last character. Check digit is calculated according to all the data, for checking if the data is correct or not.

◇ Set “No Check”, the scanner will transmit all the barcode data.



99900032
【Exit Setup】



99900031

【Start Setup】

- ◇ Set “Check but do not Send Check Digit”, the scanner will check according to the last bit, if successful, all the data except for the check digit will be transmitted, if failed, then the scanner will indicate “barcode reading failed”.
- ◇ Set “Check and Send Check Digit” the scanner will check according to the last bit, if successful, all the data including the check digit will be transmitted, the check digit will be treated as the last bit of the normal data; if failed, then the scanner will indicate “barcode reading failed”.



99911203

No Check



99911204

Check but do not Transmit the Check Character



99911205

Check and Transmit Check Character

Note: by setting “do not send the check digit”, if the data length except for the 1 character check digit is less than the minimum barcode reading limit, the barcode reading will be failed. (For example: the scanner set the the minimum barcode reading length of Interleaved2 of 5 to 4 characters and “do not send check digit”, in such circumstances,the scanner is not able to read the Interleaved2 of 5 with 4 characters.)

Set the Barcode Reading Length

The scanner is only able to read the Interleaved2 of 5 with transmission content length falls in the limited range, the range is consisted of the maximum value and minimum value in units of character (the maximum value and minimum value also included), the Interleaved2 of 5 exceeds the range can not be read or transmitted.

- ◇ Read the barcode of “Set the Minimum Length Limit” to adjust the minimum length limit.
- ◇ Read the barcode of “Set the Maximum Length Limit” to adjust the maximum length limit



99911206

Set the Minimum Length Limit



99911207

Set the Maximum Length Limit

Note : the maximum length limit of any 1D barcode must not exceed 255, if the maximum length is shorter than the minimum length, then the scanner is only able to read the barcodes with the minimum length and the the maximum length; if the maximum length equals to the minimum length, then the scanner is only able to read the barcode with such length.



99900032

【Exit Setup】



99900031
【Start Setup】

ITF-6

ITF-6 is a kind of special Interleaved2 of 5 barcode with the barcode length of 6 characters and the last character as the check character. By default, no special processing is performed on ITF-6, its setup is the same with the normal Interleaved2 of 5.

ITF-6 priority principle: if the setup of ITF-6 has been changed, then the setup of all the Interleaved2 of 5 barcode with the barcode length of 6 characters and the last character as the check character should be in accordance with ITF-6.



99911300

Restore the Default Setup Value of ITF-6



99911302

Prohibit Reading ITF-6



99911301

Allow to Read ITF-6, but do not Transmit the Check Digit



99911303

Allow to Read ITF-6 and Transmit the Check Digit

Note: if the setup of ITF-6 conflicts with the setup of Interleaved2 of 5, for example, reading ITF-6 is allowed, but reading Interleaved2 of 5 is not, according to the priority principle of ITF-6, the Interleaved2 of 5 with the barcode length of 6 characters and the last character as the check character can be read, but other Interleaved2 of 5 barcodes can not be read.

Code ID Setup

To activate the setup function by reading “CodeID setup”, then read the hexadecimal value in accordance with the character which will be set to the CodeID.



99911304

CodeID Setup

Example: Set the CodeID of ITF-6 to “p” (the hexadecimal value is 0x70).

1. Read the “Start Setup” barcode.
2. Read the “CodeID Setup” barcode.
3. Read the numeric barcode “7”, “0” (see the appendix—numeric barcode)



99900032
【Exit Setup】



99900031

【Start Setup】

4. Read the “Save” barcode.(see the appendix—numeric barcode)
5. Read the “Exit Setup” barcode.

ITF-14

ITF-14 is a kind of special Interleaved2 of 5 barcode with the barcode length of 14 characters and the last character as the check character. By default, no special processing is performed on ITF-14, its setup is the same with the normal Interleaved2 of 5.

ITF-14 priority principle: if the setup of ITF-14 has been changed, then the setup of all the Interleaved2 of 5 barcode with the barcode length of 14 characters and the last character as the check character should be in accordance with ITF-14.



99911400

Restore the Default Setup Value of ITF-14



99911402

Allow to Read ITF-14, but do not Transmit the Check Digit



99911401

Prohibit Reading ITF-14



99911403

Allow to Read ITF-14 and Transmit the Check Digit

Note: if the setup of ITF-14 conflicts with the setup of Interleaved2 of 5, for example, reading ITF-14 is allowed, but reading Interleaved2 of 5 is not; according to the priority principle of ITF-14, the Interleaved2 of 5 with the barcode length of 14 characters and the last character as the check character can be read, but other Interleaved2 of 5 barcodes can not be read. If the ITF-14 conflicts with Deutsch14 the ITF-14 will have priority to read.

CodeIDSetup

To activate the setup function by reading “CodeID setup”, then read the hexadecimal value in accordance with the character which will be set to the CodeID.



99911404

CodeID Setup

Example: Set the CodeID of ITF-14 to “p” (the hexadecimal value is 0x70).

1. Read the “Start Setup” barcode.
2. Read the “CodeID Setup” barcode.
3. Read the numeric barcode “7”, “0” (see the appendix—numeric barcode)
4. Read the “Save” barcode.(see the appendix—numeric barcode)



99900032

【Exit Setup】



99900031

【Start Setup】

5. Read the “Exit Setup” barcode.

Deutsche 14

Restore the Default Value

By reading the barcode, the parameter setup of Deutsche14 will be restored to the factory default state.



99911500

Restore the Default Setup Value of Deutsche14

Allow to Read Deutsche14 or not



99911502

Allow to Read Deutsche14, but do not send the check digit



99911501

Prohibit Reading Deutsche14



99911503

Allow to Read Deutsche14 and send the check digit

Note: the scanner will become unable to read Deutsche14 by reading the setup barcode “Prohibit Reading Deutsche14”, thus, if the scanner is unable to read the Deutsche14, please try to read the setup barcode “allow to read Deutsche14”. Deutsche 14 uses the same coding method as ITF-14 and normal ITF, so if all these are used at the same time, the misunderstanding of function setup and decoding will easily occur, thus, it is suggested to turn off the Deutsche 14 if it is not in use.

CodeID Setup

To activate the setup function by reading “CodeID setup”, then read the hexadecimal value in accordance with the character which will be set to the CodeID.



99911504

CodeID Setup

Example: Set the CodeID of Deutsche14 to “p” (the hexadecimal value is 0x70).

1. Read the “Start Setup” barcode.
2. Read the “CodeID Setup” barcode.



99900032

【Exit Setup】



99900031

【Start Setup】

3. Read the numeric barcode “7”, “0” (see the appendix—numeric barcode)
4. Read the “Save” barcode.(see the appendix—numeric barcode)
5. Read the “Exit Setup” barcode.

Deutsche 12

Restore the Default Value

By reading the barcode, the parameter setup of Deutsche12 will be restored to the factory default state.



99911600

Restore the Default Setup Value of Deutsche12

Deutsche 12 Allow to Read Deutsche 12 or not



99911602

Allow to Read Deutsche12, but do not send the check digit



99911601

Prohibit Reading Deutsche12



99911603

Allow to Read Deutsche12 and send the check digit

Note: the scanner will become unable to read Deutsche12 by reading the setup barcode “Prohibit Reading Deutsche12”, thus, if the scanner is unable to read the Deutsche12, please try to read the setup barcode “allow to read Deutsche12”. Deutsche 12 uses the same coding method as ITF-12 and normal ITF, so if all these are used at the same time, the misunderstanding of function setup and decoding will easily occur, thus, it is suggested to turn off the Deutsche 12 if it is not in use.

CodeID Setup

To activate the setup function by reading “CodeID setup”, then read the hexadecimal value in accordance with the character which will be set to the CodeID.



99900032

【Exit Setup】



99900031

【Start Setup】



99911604

CodeID Setup

Example: Set the CodeID ofDeutsche12to “p” (the hexadcimal value is 0x70).

1. Read the “Start Setup” barcode.
2. Read the “CodeID Setup” barcode.
3. Read the numeric barcode “7”, “0” (see the appendix—numeric barcode)
4. Read the “Save” barcode.(see the appendix—numeric barcode)
5. Read the “Exit Setup” barcode.

COOP 25(Japanese Matrix 2 of 5)

Restore the Default Value

By reading the barcode, the parameter setup of COOP25 will be restored to the factory default state



99911700

Restore the Default Setup Value of COOP25

Allow to Read COOP 25 or not



99911702

Allow to Read COOP25



99911701

Prohibit Reading COOP25

Note: the scanner will become unable to read COOP25 by reading the setup barcode “Prohibit Reading UCC/EAN-128”, thus, if the scanner is unable to read the COOP25, please try to read the setuo barcode “allow to read COOP25”.

CodeID Setup

To activate the setup function by reading “CodeID setup”, then read the hexadcimal value inaccordance with the character which will be set to the CodeID.



99911710

Example: Set the CodeID ofCOOP25to “p” (the hexadcimal value is 0x70).

1. Read the “Start Setup” barcode.



99900032

【Exit Setup】



99900031

【Start Setup】

2. Read the “CodeID Setup” barcode.
3. Read the numeric barcode “7”, “0” (see the appendix—numeric barcode)
4. Read the “Save” barcode.(see the appendix—numeric barcode)
5. Read the “Exit Setup” barcode.

Check Setup

COOP25 barcode data does not compulsively include the check digit, if check digit exists, then it is the last character. Check digit is calculated according to all the datas, for checking if the data is correct or not.

- ◇ Set “No Check”, the scanner will transmit all the barcode data.
- ◇ Set “Check but do not Send Check digit”, the scanner will check according to the last bit, if successful, all the data except for the check digit will be transmitted, if failed, then the scanner will indicate “barcode reading failed”
- ◇ Set “Check and Send Check digit” the scanner will check according to the last bit, if successful, all the data including the check digit will be transmitted, the check digit will be treated as the last bit of the normal data; if failed, then the scanner will indicate “barcode reading failed”



99911703

No Check



99911704

Check and Send Check Digit



99911705

Check but do not Send Check Digit

Note: by setting “do not send the check digit”, if the data length except for the 1 character check digit is less than the minimum barcode reading limit, the barcode reading will be failed. (For example: the scanner set the the minimum barcode reading length of COOP25(JapaneseMatrix2 of 5) to 4 characters and “do not send check digit”, in such circumstances,the scanner is not able to read the Deutsch12 with 4 characters.)

Set the Barcode Reading Length

The scanner is only able to read the COOP25 with transmission content length falls in the limited range, the range is consisted of the maximum value and minimum value in units of character (the maximum value and minimum value also included), the COOP25 exceeds the range can not be read or transmitted.

- ◇ Read the barcode of “Set the Minimum Length Limit” to adjust the minimum length limit.
- ◇ Read the barcode of “Set the Maximum Length Limit” to adjust the maximum length limit.



99900032

【Exit Setup】



99900031

【Start Setup】



99911706

Set the Minimum Length Limit



99911707

Set the Maximum Length Limit

Note : the maximum length limit of any 1D barcode must not exceed 255, if the maximum length is shorter than the minimum length, then the scanner is only able to read the barcodes with the minimum length and the the maximum length; if the maximum length equals to the minimum length, then the scanner is only able to read the barcode with such length.

Matrix 2 of 5 (European Matrix 2 of 5)

Restore the Default Value

By reading the barcode, the parameter setup of Matrix2 of 5 will be restored to the factory default state.



99912000

Restore the Default Setup Value of Matrix2 of 5

Restore the Default Setup Value of Matrix2 of 5



99912002

Allow to Read Matrix2 of 5



99912001

Prohibit Reading Matrix2 of 5

Note: the scanner will become unable to read Matrix2 of 5 by reading the setup barcode “Prohibit Reading Matrix2 of 5”, thus, if the scanner is unable to read the Matrix2 of 5, please try to read the setuo barcode “allow to read Matrix2 of 5”.

CodeID Setup

To activate the setup function by reading “CodeID setup”, then read the hexadcimal value inaccordance with the character which will be set to the CodeID.



99912010



99900032

【Exit Setup】



99900031

【Start Setup】

Code ID Setup

Example: Set the CodeID of Matrix 2 of 5 to “p” (the hexadecimal value is 0x70).

1. Read the “Start Setup” barcode.
2. Read the “CodeID Setup” barcode.
3. Read the numeric barcode “7”, “0” (see the appendix—numeric barcode)
4. Read the “Save” barcode.(see the appendix—numeric barcode)
5. Read the “Exit Setup” barcode.

Check Setup

Matrix 2 of 5 barcode data does not compulsively include the check digit, if check digit exists, then it is the last character. Check digit is calculated according to all the datas, for checking if the data is correct or not.

- ◇ Set “No Check”, the scanner will transmit all the barcode data
- ◇ Set “Check but do not Send Check digit”, the scanner will check according to the last bit, if successful, all the data except for the check digit will be transmitted, if failed, then the scanner will indicate “barcode reading failed”
- ◇ Set “Check and Send Check digit” the scanner will check according to the last bit, if successful, all the data including the check digit will be transmitted, the check digit will be treated as the last bit of the normal data; if failed, then the scanner will indicate “barcode reading failed”



99912003

No Check



99912004

Check and Send Check digit



99912005

Check but do not Send Check digit

Note: by setting “do not send the check digit”, if the data length except for the 1 character check digit is less than the minimum barcode reading limit, the barcode reading will be failed. (For example: the scanner set the the minimum barcode reading length of Matrix2 of 5 to 4 characters and “do not send check digit”, in such circumstances,the scanner is not able to read the Matrix2 of 5 with 4 characters.)

Set the Barcode Reading Length

The scanner is only able to read the Matrix2 of 5 with transmission content length falls in the limited range, the range is consisted of the maximum value and minimum value in units of character (the maximum value and minimum value also



99900032

【Exit Setup】



99900031

【Start Setup】

included), the Matrix2of 5 exceeds the range can not be read or transmitted.

- ◇ Read the barcode of “Set the Minimum Length Limit” to adjust the minimum length limit.
- ◇ Read the barcode of “Set the Maximum Length Limit” to adjust the maximum length limit.



99912006

Set the Minimum Length Limit



99912007

Set the Maximum Length Limit

Note : the maximum length limit of any 1D barcode must not exceed 255, if the maximum length is shorter than the minimum length, then the scanner is only able to read the barcodes with the minimum length and the the maximum length; if the maximum length equals to the minimum length, then the scanner is only able to read the barcode with such length.

Industrial 25

Restore the Default Value

By reading the barcode, the parameter setup of Industrial 25 will be restored to the factory default state.



99912100

Restore the Default Setup Value of Industrial 25

Allow to Read Deutsche 12 or not



99912102

Allow to Read Industrial 25



99912101

Prohibit Reading Industrial 25

Note: the scanner will become unable to read Industrial 25 by reading the setup barcode “Prohibit Reading Industrial 25”, thus, if the scanner is unable to read the Industrial 25, please try to read the setuo barcode “allow to read Industrial 25”.

CodeID Setup

To activate the setup function by reading “CodeID setup”, then read the hexadcimal value inaccordance with the character which will be set to the CodeID.



99912110

Code ID Setup



99900032

【Exit Setup】



99900031

【Start Setup】

Example: Set the CodeID of Industrial 25 to “p” (the hexadecimal value is 0x70).

1. Read the “Start Setup” barcode.
2. Read the “CodeID Setup” barcode.
3. Read the numeric barcode “7”, “0” (see the appendix—numeric barcode)
4. Read the “Save” barcode.(see the appendix—numeric barcode)
5. Read the “Exit Setup” barcode.

Check Setup

Industrial 25 barcode data does not compulsively include the check digit, if check digit exists, then it is the last character. Check digit is calculated according to all the datas, for checking if the data is correct or not.

- ◇ Set “No Check”, the scanner will transmit all the barcode data
- ◇ Set “Check but do not Send Check digit”, the scanner will check according to the last bit, if successful, all the data except for the check digit will be transmitted, if failed, then the scanner will indicate “barcode reading failed”
- ◇ Set “Check and Send Check digit” the scanner will check according to the last bit, if successful, all the data including the check digit will be transmitted, the check digit will be treated as the last bit of the normal data; if failed, then the scanner will indicate “barcode reading failed”



99912103

No Check



99912104

Check and Send Check digit



99912105

Check but do not Send Check digit

Note: by setting “do not send the check digit”, if the data length except for the 1 character check digit is less than the minimum barcode reading limit, the barcode reading will be failed. (For example: the scanner set the the minimum barcode reading length of Industrial 25 to 4 characters and “do not send check digit”, in such circumstances,the scanner is not able to read the Industrial 25 with 4 characters.)

Set the Barcode Reading Length

The scanner is only able to read the Industrial 25 with transmission content length falls in the limited range, the range is consisted of the maximum value and minimum value in units of character, the Industrial 25 exceeds the range can not be read or transmitted.

- ◇ Read the barcode of “Set the Minimum Length Limit” to adjust the minimum length limit.
- ◇ Read the barcode of “Set the Maximum Length Limit” to adjust the maximum length limit.



99900032

【Exit Setup】



99900031
【Start Setup】

Set the Minimum Length Limit



99912007

Set the Maximum Length Limit

Note : the maximum length limit of any 1D barcode must not exceed 255, if the maximum length is shorter than the minimum length, then the scanner is only able to read the barcodes with the minimum length and the the maximum length; if the maximum length equals to the minimum length, then the scanner is only able to read the barcode with such length.

Standard 25

Restore the Default Value

By reading the barcode, the parameter setup of Standard 25 will be restored to the factory default state.



99912200

Restore the Default Setup Value of Standard 25

Allow to Read Standard 25 or not



99912202

Allow to Read Standard 25



99912201

Prohibit Reading Standard 25

Note: the scanner will become unable to read Standard 25 by reading the setup barcode “Prohibit Reading Standard 25”, thus, if the scanner is unable to read the Standard 25, please try to read the setuo barcode “allow to read Standard 25”.

CodeID Setup

To activate the setup function by reading “CodeID setup”, then read the hexadcimal value inaccordance with the character which will be set to the CodeID.



99912210

Code ID Setup

Example: Set the CodeID ofStandard 25to “p” (the hexadcimal value is 0x70).

1. Read the “Start Setup” barcode.



99900032
【Exit Setup】



99900031

【Start Setup】

2. Read the “CodeID Setup” barcode.
3. Read the numeric barcode “7”, “0” (see the appendix—numeric barcode)
4. Read the “Save” barcode.(see the appendix—numeric barcode)
5. Read the “Exit Setup” barcode.

Read “Exit Setup Barcode”

Check Setup

Standard 25 barcode data does not compulsively include the check digit, if check digit exists, then it is the last character. Check digit is calculated according to all the datas, for checking if the data is correct or not.

- ◇ Set “No Check”, the scanner will transmit all the barcode data
- ◇ Set “Check but do not Send Check digit”, the scanner will check according to the last bit, if successful, all the data except for the check digit will be transmitted, if failed, then the scanner will indicate “barcode reading failed”
- ◇ Set “Check and Send Check digit” the scanner will check according to the last bit, if successful, all the data including the check digit will be transmitted, the check digit will be treated as the last bit of the normal data; if failed, then the
- ◇ scanner will indicate “barcode reading failed”



99912203

No Check



99912204

Check and Send Check digit



99912205

Check but do not Send Check digit

Note: by setting “do not send the check digit”, if the data length except for the 1 character check digit is less than the minimum barcode reading limit, the barcode reading will be failed. (For example: the scanner set the the minimum barcode reading length of Standard 25 to 4 characters and “do not send check digit”, in such circumstances,the scanner is not able to read the Standard 25 with 4 characters.)

Set the Barcode Reading Length

The scanner is only able to read the Standard 25 with transmission content length falls in the limited range, the range is consisted of the maximum value and minimum value in units of character, the Standard25 exceeds the range can not be read or transmitted.

- ◇ Read the barcode of “Set the Minimum Length Limit” to adjust the minimum length limit
- ◇ Read the barcode of “Set the Maximum Length Limit” to adjust the maximum length limit



99900032

【Exit Setup】



99900031
【Start Setup】

Set the Minimum Length Limit



99912207
Set the Maximum Length Limit

Note :the maximum length limit of any 1D barcode must not exceed 255, if the maximum length is shorter than the minimum length, then the scanner is only able to read the barcodes with the minimum length and the the maximum length; if the maximum length equals to the minimum length, then the scanner is only able to read the barcode with such length.

Code 39

Restore the Default Value

By reading the barcode, the parameter setup of Code 39 will be restored to the factory default state.



99912400
Restore the Default Setup Value of Code 39

Allow to Read Code 39 or not



99912402
Allow to Read Code 39



99912401
Prohibit Reading Code 39

Note: the scanner will become unable to read Code 39 by reading the setup barcode “Prohibit Reading Code 39”, thus, if the scanner is unable to read the Code 39, please try to read the setuo barcode “allow to read Code 39”.

CodeID Setup

To activate the setup function by reading “CodeID setup”, then read the hexadecimal value inaccordance with the character which will be set to the CodeID.



99912414
Code ID Setup

Example: Set the CodeID ofCode39to “p” (the hexadecimal value is 0x70).

1. Read the “Start Setup” barcode.
2. Read the “CodeID Setup” barcode.
3. Read the numeric barcode “7”, “0” (see the appendix—numeric barcode)



99900032
【Exit Setup】



99900031

【Start Setup】

4. Read the “Save” barcode.(see the appendix—numeric barcode)
5. Read the “Exit Setup” barcode.

Check Setup

Code 39 barcode data does not compulsively include the check digit, if check digit exists, then it is the last character. Check digit is calculated according to all the datas, for checking if the data is correct or not.

- ◇ Set “No Check”, the scanner will transmit all the barcode data
- ◇ Set “Check but do not Send Check digit”, the scanner will check according to the last bit, if successful, all the data except for the check digit will be transmitted, if failed, then the scanner will indicate “barcode reading failed”
- ◇ Set “Check and Send Check digit” the scanner will check according to the last bit, if successful, all the data including the check digit will be transmitted, the check digit will be treated as the last bit of the normal data; if failed, then the scanner will indicate “barcode reading failed”



99912403

No Check



99912404

Check and Send Check digit



99912405

Check but do not Send Check digit

Note: by setting “do not send the check digit”, if the data length except for the 1 character check digit is less than the minimum barcode reading limit, the barcode reading will be failed. (For example: the scanner set the the minimum barcode reading length of Code 39 to 4 characters and “do not send check digit”, in such circumstances,the scanner is not able to read the Code 39 with 4 characters.)

Set whether to Send the start and stop character or not

There are two characters of “*”before and after the Code39 barcode data as the start and stop character. The system can set whether or not to send the start and stop character after successful barcode reading.



99912407

Send the Start and the Stop Character



99912406

Do not Send the Start and the Stop Character

Set the Reading Range of ASCII Code

Code 39 can consist all the ASCII character, by default, the scanner is only able to read part of the ASCII character, by setting, the scanner can activate the function of reading the intact ASCII character.



99900032

【Exit Setup】



99900031
【Start Setup】



99912410
Turn off the Function of Reading Full ASCII



99912411
Turn on the Function of Reading Full ASCII

Set the Barcode Reading Length

The scanner is only able to read the Code 39 with transmission content length falls in the limited range, the range is consisted of the maximum value and minimum value in units of character, the Code 39 exceeds the range can not be read or transmitted.

- ◇ Read the barcode of “Set the Minimum Length Limit” to adjust the minimum length limit.
- ◇ Read the barcode of “Set the Maximum Length Limit” to adjust the maximum length limit.



Set the Minimum Length Limit
【Code : 99912412】



Set the Maximum Length Limit
【Code : 99912413】

Note :the maximum length limit of any 1D barcode must not exceed 255, if the maximum length is shorter than the minimum length, then the scanner is only able to read the barcodes with the minimum length and the the maximum length; if the maximum length equals to the minimum length, then the scanner is only able to read the barcode with such length.

Example: The steps of set the scanner read the Code 39 with barcode length between 8 to 12 characters.

1. Read the “Start Setup” barcode.
2. Read the barcode of “Set the Minimum Length Limit”.
3. Read the numeric barcode “8”, (see the appendix—numeric barcode)
4. Read the “Save” barcode.(see the appendix—numeric barcode)
5. Read the barcode of “Set the Maximum Length Limit”.
6. Read the numeric barcode “1”.
7. Read the numeric barcode “2”.
8. Read the “Save” barcode.(see the appendix—numeric barcode)
9. Read the “Exit Setup” barcode.

Codabar

Restore the Default Value

By reading the barcode, the parameter setup of Codabar will be restored to the factory default state.



99900032
【Exit Setup】



99900031

【Start Setup】



99912500

Restore the Default Setup Value of Codabar

Allow to Read Codabar or not



99912502

Allow to Read Codabar



99912501

Prohibit Reading Codabar

Note: the scanner will become unable to read Codabar by reading the setup barcode “Prohibit Reading Codabar”, thus, if the scanner is unable to read theCodabar, please try to read the setuo barcode “allow to read Codabar”.

CodeID Setup

To activate the setup function by reading “CodeID setup”, then read the hexadecimal value inaccordance with the character which will be set to the CodeID.



99912516

Code ID Setup

Example: Set the CodeID ofCodabarto “p” (the hexadecimal value is 0x70).

1. Read the “Start Setup” barcode.
2. Read the “CodeID Setup” barcode.
3. Read the numeric barcode “7”, “0” (see the appendix—numeric barcode)
4. Read the “Save” barcode.(see the appendix—numeric barcode)
5. Read the “Exit Setup” barcode.

Check Setup

Codabar barcode data does not compulsively include the check digit, if check digit exists, then it is the last character. Check digit is calculated according to all the datas, for checking if the data is correct or not.

- ◇ Set “No Check”, the scanner will transmit all the barcode data
- ◇ Set “Check but do not Send Check digit”, the scanner will check according to the last bit, if successful, all the data except for the check digit will be transmitted, if failed, then the scanner will indicate “barcode reading failed”
- ◇ Set “Check and Send Check digit” the scanner will check according to the last bit, if successful, all the data including the check digit will be transmitted, the check digit will be treated as the last bit of the normal data; if failed, then the scanner will indicate “barcode reading failed”



99900032

【Exit Setup】



99900031

【Start Setup】

No Check



99912504

Check and Send Check Digit



99912505

Check but do not Send Check Digit

Note: by setting “do not send the check digit”, if the data length except for the 1 character check digit is less than the minimum barcode reading limit, the barcode reading will be failed. (For example: the scanner set the the minimum barcode reading length of Codabar to 4 characters and “do not send check digit”, in such circumstances,the scanner is not able to read the Codabar with 4 characters.)

Start and Stop Character Setup



99912506

Do not Send the Start and Stop Character



99912507

Send the Start and Stop Character



99912510

Set “ABCD/ABCD” as the Start and Stop Character



99912511

Set “ABCD/TN*E” as the Start and Stop Character



99912512

Set “abcd/abcd” as the Start and Stop Character



99912513

Set “abcd/tn*e” as the Start and Stop Character

Set the Barcode Reading Length

The scanner is only able to read the Codabar with transmission content length falls in the limited range, the range is consisted of the maximum value and minimum value in units of character, the Codabar exceeds the range can not be read or transmitted.

- ◇ Read the barcode of “Set the Minimum Length Limit” to adjust the minimum length limit.
- ◇ Read the barcode of “Set the Maximum Length Limit” to adjust the maximum length limit.



99900032

【Exit Setup】



99900031

【Start Setup】



99912514

Set the Minimum Length Limit



99912515

Set the Maximum Length Limit

Note : the maximum length limit of any 1D barcode must not exceed 255, if the maximum length is shorter than the minimum length, then the scanner is only able to read the barcodes with the minimum length and the the maximum length; if the maximum length equals to the minimum length, then the scanner is only able to read the barcode with such length.

Example: The steps of set the scanner read the Codabarwith barcode length between 8 to 12 characters.

1. Read the “Start Setup” barcode.
2. Read the barcode of “Set the Minimum Length Limit”.
3. Read the numeric barcode “8”, (see the appendix—numeric barcode)
4. Read the “Save” barcode.(see the appendix—numeric barcode)
5. Read the barcode of “Set the Maximum Length Limit”.
6. Read the numeric barcode “1”.
7. Read the numeric barcode “2”.
8. Read the “Save” barcode.(see the appendix—numeric barcode)
9. Read the “Exit Setup” barcode.

Code 93

Restore the Default Value

By reading the barcode, the parameter setup of Code 93 will be restored to the factory default state.



99912600

Restore the Default Setup Value of Code 93

Allow to Read Code 93 or not



99912602

Allow to Read Code 93



99912601

Prohibit Reading Code 93

Note: the scanner will become unable to read Code 93 by reading the setup barcode “Prohibit Reading Code 93”, thus, if the scanner is unable to read the Code 93, please try to read the setuo barcode “allow to read Code 93”.



99900032

【Exit Setup】



99900031
【Start Setup】

CodeID Setup

To activate the setup function by reading “CodeID setup”, then read the hexadecimal value in accordance with the character which will be set to the CodeID.



Code ID Setup

Example: Set the CodeID of Code 93 to “p” (the hexadecimal value is 0x70).

1. Read the “Start Setup” barcode.
2. Read the “CodeID Setup” barcode.
3. Read the numeric barcode “7”, “0” (see the appendix—numeric barcode)
4. Read the “Save” barcode.(see the appendix—numeric barcode)
5. Read the “Exit Setup” barcode.

Check Setup

Code 93 barcode data does not compulsively include the check digit, if check digit exists, then it is the last character. Check digit is calculated according to all the datas, for checking if the data is correct or not.

- ◇ Set “No Check”, the scanner will transmit all the barcode data
- ◇ Set “Check but do not Send Check digit”, the scanner will check according to the last bit, if successful, all the data except for the check digit will be transmitted, if failed, then the scanner will indicate “barcode reading failed”
- ◇ Set “Check and Send Check digit” the scanner will check according to the last bit, if successful, all the data including the check digit will be transmitted, the check digit will be treated as the last bit of the normal data; if failed, then the scanner will indicate “barcode reading failed”



No Check



Check and Send Check Digit



Check but do not Send Check Digit

Note: by setting “do not send the check digit”, if the data length except for the 1 character check digit is less than the minimum barcode reading limit, the barcode reading will be failed. (For example: the scanner set the the minimum barcode reading length of Code 93 to 4 characters and “do not send check digit”, in such circumstances,the scanner is not



99900032
【Exit Setup】



99900031

【Start Setup】

able to read the Code 93 with 4 characters.)

Set the Barcode Reading Length

The scanner is only able to read the Code 93 with transmission content length falls in the limited range, the range is consisted of the maximum value and minimum value in units of character (the maximum value and minimum value also included), the Code 93 exceeds the range can not be read or transmitted.

- ◇ Read the barcode of “Set the Minimum Length Limit” to adjust the minimum length limit.
- ◇ Read the barcode of “Set the Maximum Length Limit” to adjust the maximum length limit.
- ◇



99912606

Set the Minimum Length Limit



99912607

Set the Maximum Length Limit

Note : the maximum length limit of any 1D barcode must not exceed 255, if the maximum length is shorter than the minimum length, then the scanner is only able to read the barcodes with the minimum length and the the maximum length; if the maximum length equals to the minimum length, then the scanner is only able to read the barcode with such length.

Code 11

Restore the Default Value

By reading the barcode, the parameter setup of Code 11 will be restored to the factory default state.



99912700

Restore the Default Setup Value of Code 11

Allow to Read Code 11 or not



99912702

Allow to Read Code 11



99912701

Prohibit Reading Code 11

Note: the scanner will become unable to read Code 11 by reading the setup barcode “Prohibit Reading Code 11”, thus, if the scanner is unable to read the Code 11, please try to read the setuo barcode “allow to read Code 11”.



99900032

【Exit Setup】



99900031
【Start Setup】

CodeID Setup

To activate the setup function by reading “CodeID setup”, then read the hexadecimal value in accordance with the character which will be set to the CodeID.



Code ID Setup

Example: Set the CodeID of Code 11 to “p” (the hexadecimal value is 0x70).

1. Read the “Start Setup” barcode.
2. Read the “CodeID Setup” barcode.
3. Read the numeric barcode “7”, “0” (see the appendix—numeric barcode)
4. Read the “Save” barcode.(see the appendix—numeric barcode)
5. Read the “Exit Setup” barcode.

Check Setup

Code 11 barcode data does not compulsively include the check digit, if check digit exists, then it is the last character. Check digit is calculated according to all the datas, for checking if the data is correct or not.

Set “No Check”, the scanner will transmit all the barcode data.



No Check



One Digit Check, MOD11



Two Digits Check, MOD11/MOD11



Two Digits Check, MOD11/MOD9



MOD11 Single Check (Len<=10)
MOD11/MOD11 Double Check (Len>10)



MOD11 Single Check (Len<=10)
MOD11/MOD9 Double Check (Len>10)



99900032
【Exit Setup】



99900031

【Start Setup】

Do not Send the Check Digit



99912712

Send the Check Digit

Note: by setting “do not send the check digit”, if the data length except for the 1 character check digit is less than the minimum barcode reading limit, the barcode reading will be failed. (For example: the scanner set the the minimum barcode reading length of Code 11 to 4 characters and “do not send check digit”, in such circumstances,the scanner is not able to read the Code 11 with 4 characters.)

Set the Barcode Reading Length

The scanner is only able to read the Code 11 with transmission content length falls in the limited range, the range is consisted of the maximum value and minimum value in units of character (the maximum value and minimum value also included), the Code 11 exceeds the range can not be read or transmitted.

- ◇ Read the barcode of “Set the Minimum Length Limit” to adjust the minimum length limit.
- ◇ Read the barcode of “Set the Maximum Length Limit” to adjust the maximum length limit.



99912713

Set the Minimum Length Limit



99912714

Set the Maximum Length Limit

Note : the maximum length limit of any 1D barcode must not exceed 255, if the maximum length is shorter than the minimum length, then the scanner is only able to read the barcodes with the minimum length and the the maximum length; if the maximum length equals to the minimum length, then the scanner is only able to read the barcode with such length.

Example: The steps of set the scanner read the Code 11 with barcode length between 8 to 12 characters.

1. Read the “Start Setup” barcode.
2. Read the barcode of “Set the Minimum Length Limit”.
3. Read the numeric barcode “8”, (see the appendix—numeric barcode)
4. Read the “Save” barcode.(see the appendix—numeric barcode)
5. Read the barcode of “Set the Maximum Length Limit”.
6. Read the numeric barcode “1”.
7. Read the numeric barcode “2”.
8. Read the “Save” barcode.(see the appendix—numeric barcode)
9. Read the “Exit Setup” barcode.



99900032

【Exit Setup】



99900031
【Start Setup】

Plessey

Restore the Default Value

By reading the barcode, the parameter setup of Plessey will be restored to the factory default state.



Restore the Default Setup Value of Plessey

Allow to Read Plessey or not



Allow to Read Plessey



Prohibit Reading Plessey

Note: the scanner will become unable to read Plessey by reading the setup barcode “Prohibit Reading Plessey”, thus, if the scanner is unable to read the Plessey, please try to read the setuo barcode “allow to read Plessey”.

CodeID Setup

To activate the setup function by reading “CodeID setup”, then read the hexadecimal value inaccordance with the character which will be set to the CodeID.



Code ID Setup

Example: Set the CodeID ofPlesseyto “p” (the hexadecimal value is 0x70).

1. Read the “Start Setup” barcode.
2. Read the “CodeID Setup” barcode.
3. Read the numeric barcode “7”, “0” (see the appendix—numeric barcode)
4. Read the “Save” barcode.(see the appendix—numeric barcode)
5. Read the “Exit Setup” barcode.

Check Setup

Plessey barcode data does not compulsively include the check digit, if check digit exists, then it is the last character. Check digit is calculated according to all the datas, for checking if the data is correct or not.

- ◇ Set “No Check”, the scanner will transmit all the barcode data
- ◇ Set “Check but do not Send Check digit”, the scanner will check according to the last bit, if successful, all the data except for the check digit will be transmitted, if failed, then the scanner will indicate “barcode reading failed”



99900032
【Exit Setup】



99900031

【Start Setup】

Set “Check and Send Check digit” the scanner will check according to the last bit, if successful, all the data including the check digit will be transmitted, the check digit will be treated as the last bit of the normal data; if failed, then the scanner will indicate “barcode reading failed”



99913003

No Check



99913004

Check and Send Check digit



99913005

Check but do not Send Check digit

Note: by setting “do not send the check digit”, if the data length except for the 1 character check digit is less than the minimum barcode reading limit, the barcode reading will be failed. (For example: the scanner set the the minimum barcode reading length of Plessey to 4 characters and “do not send check digit”, in such circumstances,the scanner is not able to read the Plessey with 4 characters.)

Set the Barcode Reading Length

The scanner is only able to read the Plessey with transmission content length falls in the limited range, the range is consisted of the maximum value and minimum value in units of character, the Plessey exceeds the range can not be read or transmitted.

- ◇ Read the barcode of “Set the Minimum Length Limit” to adjust the minimum length limit.
- ◇ Read the barcode of “Set the Maximum Length Limit” to adjust the maximum length limit.



99913006

Set the Minimum Length Limit



99913007

Set the Maximum Length Limit

Note : the maximum length limit of any 1D barcode must not exceed 255, if the maximum length is shorter than the minimum length, then the scanner is only able to read the barcodes with the minimum length and the the maximum length; if the maximum length equals to the minimum length, then the scanner is only able to read the barcode with such length.

MSI-Plessey

Restore the Default Value

By reading the barcode, the parameter setup ofMSI-Plessey will be restored to the factory default state.



99900032

【Exit Setup】



99900031
【Start Setup】



99913100

Restore the Default Setup Value of MSI-Plessey

Allow to Read MSI-Plessey or not



99913102

Allow to Read MSI-Plessey



99913101

Prohibit Reading MSI-Plessey

Note: the scanner will become unable to read MSI-Plessey by reading the setup barcode “Prohibit Reading MSI-Plessey”, thus, if the scanner is unable to read the MSI-Plessey, please try to read the setuo barcode “allow to read MSI-Plessey”.

CodeID Setup

To activate the setup function by reading “CodeID setup”, then read the hexadcimal value inaccordance with the character which will be set to the CodeID.



99913113

Code ID Setup

Example: Set the CodeID ofMSI-Plesseyto “p” (the hexadcimal value is 0x70).

1. Read the “Start Setup” barcode.
2. Read the “CodeID Setup” barcode.
3. Read the numeric barcode “7”, “0” (see the appendix—numeric barcode)
4. Read the “Save” barcode.(see the appendix—numeric barcode)
5. Read the “Exit Setup” barcode.

Check Setup

MSI-Plessey barcode data does not compulsively include the check digit, if check digit exists, then it is the last character. Check digit is calculated according to all the datas, for checking if the data is correct or not.

Set “No Check”, the scanner will transmit all the barcode data



99900032
【Exit Setup】



99900031

【Start Setup】

No Check



99913104

Single Check MOD10



99913105

Double Check MOD10/MOD10



99913106

Double Check MOD10/MOD11



99913107

Do not Send the Check Digit



99913110

Send the Check Digit

Note: by setting “do not send the check digit”, if the data length except for the 1 character check digit is less than the minimum barcode reading limit, the barcode reading will be failed. (For example: the scanner set the the minimum barcode reading length of MSI-Plessey to 4 characters and “do not send check digit”, in such circumstances,the scanner is not able to read the MSI-Plessey with 4 characters.)

Set the Barcode Reading Length

The scanner is only able to read the MSI-Plessey with transmission content length falls in the limited range, the range is consisted of the maximum value and minimum value in units of character, the MSI-Plessey exceeds the range can not be read or transmitted.

- ◇ Read the barcode of “Set the Minimum Length Limit” to adjust the minimum length limit
- ◇ Read the barcode of “Set the Maximum Length Limit” to adjust the maximum length limit



99913111

Set the Minimum Length Limit



99913112

Set the Maximum Length Limit

Note :the maximum length limit of any 1D barcode must not exceed 255, if the maximum length is shorter than the minimum length, then the scanner is only able to read the barcodes with the minimum length and the the maximum length; if the maximum length equals to the minimum length, then the scanner is only able to read the barcode with such length.



99900032

【Exit Setup】



99900031
【Start Setup】

GS1 Databar

Restore the Default Value

By reading the barcode, the parameter setup of GS1 Databar will be restored to the factory default state.



99913200

Restore the Default Setup Value of GS1 Databar

Allow to Read GS1 Databar or not



99913202

Allow to Read GS1 Databar



99913201

Prohibit Reading GS1 Databar

Note: the scanner will become unable to read GS1 Databar by reading the setup barcode “Prohibit Reading GS1 Databar”, thus, if the scanner is unable to read the GS1 Databar, please try to read the setuo barcode “allow to read GS1 Databar”.

CodeID Setup

To activate the setup function by reading “CodeID setup”, then read the hexadcimal value inaccordance with the character which will be set to the CodeID.



99913203

Code ID Setup

Example: Set the CodeID ofGS1 Databarto “p” (the hexadcimal value is 0x70).

1. Read the “Start Setup” barcode.
2. Read the “CodeID Setup” barcode.
3. Read the numeric barcode “7”, “0” (see the appendix—numeric barcode)
4. Read the “Save” barcode.(see the appendix—numeric barcode)
5. Read the “Exit Setup” barcode.

PDF417

Restore the Default Value

By reading the barcode, the parameter setup of PDF417 will be restored to the factory default state.



99920100



99900032
【Exit Setup】



99900031
【Start Setup】

Restore the Default Setup Value of PDF417

Allow to Read PDF417 or not



99920102
Allow to Read PDF417



99920101
Prohibit Reading PDF417

Note: the scanner will become unable to read PDF417 by reading the setup barcode “Prohibit Reading PDF417”, thus, if the scanner is unable to read the PDF417, please try to read the setuo barcode “allow to read PDF417”.

Note: PDF417 can support the barcode with maximum 48 lines x 18 rows.

CodeID Setup

To activate the setup function by reading “CodeID setup”, then read the hexadecimal value in accordance with the character which will be set to the CodeID.



99920115
Code ID Setup

Example: Set the CodeID ofPDF417to “p” (the hexadecimal value is 0x70).

1. Read the “Start Setup” barcode.
2. Read the “CodeID Setup” barcode.
3. Read the numeric barcode “7”, “0” (see the appendix—numeric barcode)
4. Read the “Save” barcode.(see the appendix—numeric barcode)
5. Read the “Exit Setup” barcode.

MicroPDF417

Restore the Default Value

By reading the barcode, the parameter setup of MicroPDF417 will be restored to the factory default state.



99921100
Restore the Default Setup Value of MicroPDF417

Allow to Read MicroPDF417 or not



99900032
【Exit Setup】



99900031

【Start Setup】

Allow to Read MicroPDF417



99921102

Prohibit Reading MicroPDF417

Note: the scanner will become unable to read MicroPDF417 by reading the setup barcode “Prohibit Reading MicroPDF417”, thus, if the scanner is unable to read the MicroPDF417, please try to read the setup barcode “allow to read MicroPDF417”.

Note: MicroPDF417 support the barcode with maximum 255 bytes.

CodeID Setup

To activate the setup function by reading “CodeID setup”, then read the hexadecimal value in accordance with the character which will be set to the CodeID.



99921115

Code ID Setup

Example: Set the CodeID of MicroPDF417 to “p” (the hexadecimal value is 0x70).

1. Read the “Start Setup” barcode.
2. Read the “CodeID Setup” barcode.
3. Read the numeric barcode “7”, “0” (see the appendix—numeric barcode)
4. Read the “Save” barcode.(see the appendix—numeric barcode)
5. Read the “Exit Setup” barcode.



99900032

【Exit Setup】



99900031

【Start Setup】

Chapter 7 Appendix

Default Setup Table

| Parameters | Default Setup | Remark |
|--|-------------------------------------|----------------------------------|
| General Setup | | |
| Setup Barcode Function | On | |
| Send Setup Barcode | Off | |
| Working Mode | Manual Reading | |
| Wireless Communication Mode | Asynchronized Mode | |
| Set the Barcode Reading Time | 15 Seconds | Range: 0-15sec, 0 means non-stop |
| Set the Time Interval between Scanning | 1 second | Range: 0-7.5sec |
| Sensitivity Level | High Sensibility | Effective in Sensitivity Mode |
| Security Level | Level 1 | |
| Decoding Sound | Intermediate Frequency-Loud,(150ms) | Tone fo Successful Reading |
| Read the Same Barcode successivly | Off | Effective in Auto-Mode |
| Re-Timing after Successful Reading | On | Effective in Auto-Mode |
| Communication Setup | | |
| Baud Rate | 9600 | |
| Serial Port Data Check | No Check | |
| Stop Bit | 1 bit | |
| Flow Control | Off | |
| Data Bits | 8 bits | |
| USB Virtual Keyboard | On | |



99900032

【Exit Setup】



99900031

【Start Setup】

| Parameters | Default Setup | Remark |
|--------------------------------|--------------------------------------|---|
| Virtual Keyboard Layout | The First, American English keyboard | |
| Delay between Characters | 0ms | 0~75ms |
| Character Conversion | No conversion | |
| Number Lockup | Off | |
| Data Format Setup | | |
| Setup of the Prefix sequence | CodeID+Custom+AIMID | CodeID+Prefix+(AIMID+Data) +Suffix+Terminal |
| Add AIMID Prefix | Off | ¡Cm Symbol |
| Add CodeID | Off | 1 or 2 Character, Captital or Lowercase Letter |
| Add Custom Prefix | Off | The Maximum is 11 characters |
| Add Custom Suffix | Off | The Maximum is 11 characters |
| Barcode Parameter Setup | | |
| Code128 | | |
| Enable | On | |
| Maximum Length | 255 | |
| Minmum Length | 1 | |
| UCC/EAN-128 | | |
| Enable | On | |
| Maximum Length | 255 | |
| Minmum Length | 1 | |
| AIM128 | | |
| Enable | Off | |
| Minmum Length | 1 | |
| EAN-8 | | |



99900032

【Exit Setup】



99900031

【Start Setup】

| Parameters | Default Setup | Remark |
|---------------------------------|---------------|--------|
| Enable | On | |
| Send the Check Character | On | |
| Read 2-Digits Extracode | Off | |
| Read 5-Digits Extracode | Off | |
| Extracode is Required, 2-digits | Off | |
| Extracode is Required, 5-digits | Off | |
| Extend to EAN-13 | Off | |
| Type is EAN-13 when Extend | Off | |
| EAN-13 | | |
| Enable | On | |
| Send the Check Character | On | |
| Read 2-Digits Extracode | Off | |
| Read 5-Digits Extracode | Off | |
| Extracode is Required, 2-digits | Off | |
| Extracode is Required, 5-digits | Off | |
| ISSN | | |
| Enable | Off | |
| ISBN | | |
| Enable | Off | |
| Use 10 digits ISBN | Off | |
| UPC-E | | |
| Enable | On | |
| Send the Check Character | On | |
| Read 2-Digits Extracode | Off | |



99900032

【Exit Setup】



99900031

【Start Setup】

| Parameters | Default Setup | Remark |
|---------------------------------|---------------|--------|
| Read 5-Digits Extracode | Off | |
| Extracode is Required, 2-digits | Off | |
| Extracode is Required, 5-digits | Off | |
| Extend to UPC-A | Off | |
| Type is UPC-A when Extend | Off | |
| Send the System Digit "0" | | |
| UPC-A | | |
| Enable | On | |
| Send the Check Character | On | |
| Read 2-Digits Extracode | Off | |
| Read 5-Digits Extracode | Off | |
| Extracode is Required, 2-digits | Off | |
| Extracode is Required, 5-digits | Off | |
| Send the System Digit "0" | | |
| Interleaved 2 of 5 | | |
| Enable | On | |
| Check | On | |
| Send Check Character | Off | |
| Maximum Length | 255 | |
| Minmum Length | 6 | |
| ITF-6 | | |
| Enable | Off | |
| Send Check Character | On | |
| ITF-14 | | |



99900032

【Exit Setup】



99900031

【Start Setup】

| Parameters | Default Setup | Remark |
|--|---------------|-----------|
| Enable | Off | |
| Send Check Character | On | |
| Deutsche 14 | | |
| Enable | Off | |
| Send Check Character | On | |
| Deutsche 12 | | |
| Enable | Off | |
| Send Check Character | On | |
| COOP25 (JapaneseMatrix 2 of 5) | | |
| Enable | Off | |
| Check | Off | |
| Send Check Character | Off | |
| Maximum Length | 255 | |
| Minmum Length | 6 | |
| Matrix 2 of 5(European Matrix 2 of 5) | | |
| Enable | On | |
| Check | Off | |
| Send Check Character | Off | |
| Maximum Length | 255 | |
| Minmum Length | 6 | At less 3 |
| Industrial 25 | | |
| Enable | ? | |
| Check | ? | |
| Send Check Character | ? | |



99900032

【Exit Setup】



99900031

【Start Setup】

| Parameters | Default Setup | Remark |
|---|---------------|------------|
| Maximum Length | ? | |
| Minmum Length | ? | |
| Standard 25 | | |
| Enable | On | |
| Check | Off | |
| Send Check Character | Off | |
| Maximum Length | 255 | |
| Minmum Length | 6 | At less 4 |
| Code 39 | | |
| Enable | On | |
| Check | Off | |
| Send Check Character | Off | |
| Do not Send Start and Stop Character | Off | |
| Support Full ASCII | On | |
| Maximum Length | 255 | |
| Minmum Length | 4 | |
| Codabar | | |
| Enable | On | |
| Check | Off | |
| Send Check Character | Off | |
| Do not Send Start and Stop Character | Off | Select one |
| ABCD/ABCD as the Start and Stop Character | On | |



99900032

【Exit Setup】



| Parameters | Default Setup | Remark |
|---|---------------|-----------|
| ABCD/TN*E as the Start and Stop Character | Off | |
| abcd/abcd as the Start and Stop Character | Off | |
| abcd/tn*e as the Start and Stop Character | Off | |
| Maximum Length | 255 | |
| Minmum Length | 4 | At less 2 |
| Code 93 | | |
| Enable | On | |
| Check | On | |
| Send Check Character | Off | |
| Maximum Length | 255 | |
| Minmum Length | 2 | At less 1 |
| Code 11 | | |
| Enable | Off | |
| Check | Off | |
| Send Check Character | On | |
| 1 Digit MOD10 Check | On | |
| 2 Digits MOD10/MOD10 Check | Off | |
| 2 Digits MOD10/MOD11 Check | Off | |
| Auto 2 Digits MOD11/MOD11 | Off | |
| Auto 2 Digits MOD11/MOD9 | Off | |
| Maximum Length | 255 | |
| Minmum Length | 4 | At less 3 |
| Plessey | | |





99900031

【Start Setup】

| Parameters | Default Setup | Remark |
|----------------------------|---------------|-----------|
| Enable | Off | |
| Check | On | |
| Send Check Character | Off | |
| Maximum Length | 255 | |
| Minmum Length | 4 | At less 4 |
| MSI-Plessey | | |
| Enable | Off | |
| Check | Off | |
| Send Check Character | On | |
| 1 Digit MOD10 Check | Off | |
| 2 Digits MOD10/MOD10 Check | Off | |
| 2 Digits MOD10/MOD11 Check | Off | |
| Maximum Length | 255 | |
| Minmum Length | 4 | At less 3 |
| GS1 Databar | | |
| Enable | On | |
| PDF417 | | |
| Enable | On | |
| MicroPDF417 | | |
| Enable | On | |



99900032

【Exit Setup】



99900031

【Start Setup】

AIM ID Table

| Barcode | AIM ID | Possible AIM ID Parameters |
|---------------------------------------|--------|----------------------------|
| Code 128 |]C0 | |
| UCC/EAN-128 |]C1 | |
| AIM 128 |]C2 | |
| ISBT 128 |]C4 | |
| EAN-8 |]E4 | |
| EAN-13 |]E0 | |
| EAN-13 with Addon |]E3 | |
| ISSN |]X0 | |
| ISBN |]X0 | |
| UPC-E |]E0 | |
| UPC-E with Addon |]E3 | |
| UPC-A |]E0 | |
| UPC-A with Addon |]E3 | |
| Interleaved 2 of 5 |]Im | 0,1,3 |
| ITF-6 |]Im | 1,3 |
| ITF-14 |]Im | 1,3 |
| Deutsche 14 |]X0 | |
| Deutsche 12 |]X0 | |
| COOP 25 (Japanese Matrix 2 of 5) |]X0 | |
| Matrix 2 of 5(European Matrix 2 of 5) |]X0 | |
| Industrial 25 |]S0 | |



99900032

【Exit Setup】



99900031

【Start Setup】

| | | |
|-------------|-----|-------------|
| Standard 25 | JR0 | |
| Code 39 | JAm | 0,1,3,4,5,7 |
| Codabar | JFm | 0,2,4 |
| Code 93 | JG0 | |
| Code 11 | JHm | 0,1,3 |
| Plessey | JP0 | |
| MSI-Plessey | JMm | 0,1 |
| GS1 Databar | Je0 | |
| PDF417 | JLm | 0,1,2 |
| MicroPDF417 | JLm | 3,4,5 |

Reference:

1. ISO/IEC 15424:2008
2. Information Technology - Auto-Identification and Data Collection Technology – Data Carrier Identifiers (including the symbol identifiers)



99900032

【Exit Setup】



99900031

【Start Setup】

CodeID Table

| 条码类型 Barcode | Code ID |
|---------------------------------------|---------|
| Code 128 | j |
| UCC/EAN-128 | u |
| AIM 128 | f |
| ISBT 128 | t |
| EAN-8 | g |
| EAN-13 | d |
| ISSN | n |
| ISBN | B |
| UPC-E | h |
| UPC-A | c |
| Interleaved 2 of 5 | e |
| ITF-6 | r |
| ITF-14 | q |
| Deutsche 14 | w |
| Deutsche 12 | l |
| COOP 25 (Japanese Matrix 2 of 5) | o |
| Matrix 2 of 5(European Matrix 2 of 5) | v |
| Industrial 25 | i |
| Standard 25 | s |
| Code 39 | b |
| Codabar | a |
| Code 93 | y |



99900032

【Exit Setup】



99900031

【Start Setup】

| | |
|-------------|---|
| Code 11 | z |
| Plessey | p |
| MSI-Plessey | m |
| GS1 Databar | R |
| PDF417 | P |
| MicroPDF417 | M |

Data Barcode

After reading the data barcode, please read “save” in the next page to save the data barcode setup.



99900000

0



99900004

4



99900001

1



99900005

5



99900002

2



99900006

6



99900003

3



99900007

7



99900010

8



99900011

9



99900032

【Exit Setup】



99900031

【Start Setup】



99900012

A



99900013

B



99900014

C



99900015

D



99900016

E



99900017

F

Save and Abort the Setup

After reading the data barcode, please read “save” to save the data. If reading error occurs, except for re-configuration, the customer can also abort the error data.

If the scanner has read a certain setup barcode, and read numeric data “1” , “2” , “3” according to priority, after that, If the scanner read “Abort the Last Data”, then the last digit “3” will be aborted, if read “Abort a String of Data”, then the data “123” will be aborted, if read “Abort the Present Setup”, then the data “123” and the setup barcode will all be aborted, and the scanner is still in the state of “Enter Setup Barcode”.



99900020

Save Data Parameter



99900023

Abort the Present Command



99900021

Abort one of the Presnet Setup of the Data Parameter



99900022

Abort one of the Presnet Setup of the Data Parameter



99900032

【Exit Setup】